

General Specifications

AXFA14 Magnetic Converter for Remote Flowtube



GS 01E20C02-02E-A

The AXFA14 magnetic converter has been developed based on Yokogawa's decades long experience in magnetic flowmeters. The AXFA14 continues the tradition of high quality and reliability that has become synonymous with the Yokogawa name and in addition features an even higher level of performance and increased functionality.

Retaining all the features and functions of the Admag series of converters, in addition the AXFA14 offers an enhanced dual frequency excitation method as an option for difficult applications as well as new diagnostics to detect electrode coating. Combined with a flowtube utilizing the optional replaceable electrode design, the user benefits through the ability to schedule maintenance for reduced process downtime and in turn a lower total cost of ownership.

Note: The "Dual Frequency Excitation Method" is Yokogawa's unique technology.



■ FEATURES

• **Optional enhanced dual frequency excitation method**

The user can select a 165 Hz high frequency component for very high concentration slurries to ensure greater stability and quicker response.

• **Minimum fluid conductivity of 1 μ S/cm**

With the newly designed AXF flow converter, improvements to the input circuit now permit the measurement of fluids with conductivity as low as 1 μ S/cm.

• **Diagnostics to detect insulating coatings on the electrodes**

By constantly monitoring the change in the impedance of the electrode circuit due to the build-up of insulating coatings, the AXF converter will display 4 different levels of coating and provide an alarm function.

• **Improved accuracy specification**

The standard performance specification for AXF is 0.35% of reading. Also available is an optional high accuracy calibration rated at 0.2% of reading.

• **Three line display with infrared switches**

The LCD indicator employs a large, backlit, full dot matrix display. One to three lines are available and these can be programmed to indicate a wide variety of display possibilities, including a bar graph for flow rate indication and a graphical representation of the extent to which the electrodes may be coating. Infrared switches permit programming through the glass without the need to open the enclosure cover.

• **High speed pulse output**

The pulse output can be programmed up to 10,000 pulses/second for high-speed applications such as short batch processes.

• **"Easy Setup" Parameters**

The most frequently used parameters are arranged in one location for easy, quick access.

CONTENTS

Features	P. 1
Standard Specifications	P. 2
Hazardous Area Classification	P. 4
Standard Performance	P. 4
Normal Operating Conditions	P. 5
Accessories	P. 5
Model and Suffix Code	P. 6
Terminal Configuration, Terminal Wiring	P. 6
Optional Specifications for AXFA14 Remote Converter	P. 7
External Dimensions	P. 8
Ordering Information	P. 8

■ STANDARD SPECIFICATIONS

Excitation Method

- Standard dual frequency excitation:
Size 2.5 to 400 mm (0.1 to 16 in.)
Combined with AXF Remote Flowtube
- Enhanced dual frequency excitation:
Size 25 to 200 mm (1.0 to 8.0 in.)
Combined with AXF Remote Flowtube
(Option code HF2)

Input Signal:

One Status Input: Dry contact
Load resistance: 200 Ω or less (ON), 100 kΩ or more (OFF)

Output Signals(*1):

- One Current Output: 4 to 20 mA DC (load resistance: 0 to 750 Ω, including cable resistance)
- One Pulse Output (*1):
Transistor contact output (open collector)
Contact capacity: 30 V DC (OFF), 200 mA (ON)
Output rate 0.0001 to 10,000 pps (pulse/second)
- One Alarm Output (*1):
Transistor contact output (open collector)
Contact capacity: 30 V DC (OFF), 200 mA (ON)
- Two Status Outputs (*1):
Transistor contact output (open collector)
Contact capacity: 30 V DC (OFF), 200 mA (ON)

Communication Signals:

BRAIN or HART communication signal
(Superimposed on the 4 to 20 mA DC signal)

Communication Line Conditions:

Load resistance: 250 to 600 Ω (including cable resistance)
Distance from power line: 15 cm (6 in.) or more (Parallel wiring should be avoided.)

BRAIN:

Communication Distance:

Up to 2 km (1.25 miles), when polyethylene insulated PVC-sheathed cables (CEV cables) are used.
Communication distance varies depending on the type of cable and wiring used.

Load Resistance: 250 to 600 Ω (including cable resistance)

Load Capacitance: 0.22 μF or less

Load Inductance: 3.3 mH or less

Input Impedance of Communicating Device:

10 kΩ or more (at 24 kHz)

HART:

Communication Distance:

Up to 1.5 km (0.9 mile), when using multiple twisted pair cables. Communication distance varies depending on the type of cable used.

Load Resistance: 250 to 600 Ω (including cable resistance)

Note 1: See "Terminal Wiring" on page 6 for possible input/output combinations.

Cable Length for Specific Applications:

Use the following formula to determine the cable length for specific applications:

$$L = \frac{65 \times 10^6}{(R \times C)} - \frac{(C_f + 10,000)}{C}$$

where:

L = length in meters or feet

R = resistance in Ω (including barrier resistance)

C = cable capacitance in pF/m or pF/ft

C_f = maximum shunt capacitance of receiving devices in pF/m or pF/ft

Note: HART is a registered trademark of the HART Communication Foundation.

Data Security During Power Failure:

Data (parameters, totalizer value, etc.) storage by EEPROM. No back-up battery required.

Indicator:

Full dot-matrix LCD (32×132 pixels)

Lightning Protector:

A lightning protector is built into the excitation current output, the current output, pulse/alarm/status input and output terminals. If option code A is selected, the lightning protector is built into the power terminals.

Protection:

IP67, NEMA4X

Coating:

Case and Cover: Polyurethane corrosion-resistant
Coating Color: Mint green (Munsell 5.6 BG 3.3/2.9 or its equivalent)

Converter Material:

Case and Cover: Aluminum alloy

Mounting: 2 inch pipe

Electrical Connection:

ANSI 1/2 NPT female

Terminal Connection:

M4 size screw terminal

Grounding:

Grounding resistance 100 Ω or less

When option code A is selected, Class C grounding (grounding resistance 10 Ω or less) shall be applied.

* In case of explosion proof type, the protective grounding must be connected to a suitable IS grounding system.

Converter Interchange:

In instances where the AXFA14 converter has been paired with a remote AXF flowtube and the converter is changed to the AXFA11 converter, a flow calibration must be performed to arrive at the meter factors for the new combination. The AXFA14 converter can only be combined with remote flowtubes size 2.5 - 400 mm (0.1 to 16 in.) For 250 mm (10 in.) or larger used in low conductivity fluids or high concentration slurry, please use the AXFA11 converter.

Functions

How to Set Parameters:

The indicator's LCD and three infra-red switches enable users to set parameters without opening the case cover. Parameters can also be set by means of the HHT.

Displayed Languages:

English, Japanese, German, French, Italian, and Spanish.

Instantaneous Flow Rate/Totalized Value Display

Functions (for models with an indicator):

The full dot-matrix LCD enables user selection of displays from one line to three lines for:

- Instantaneous flow rate
- Instantaneous flow rate (%)
- Instantaneous flow rate (bar graph)
- Current output value (mA)
- Totalized value
- Tag No.
- Results of electrode coating diagnostics

Totalizer Display Function:

For forward/reverse ranges, the totalized values of the flow direction (forward or reverse) and the flow rate are displayed on the indicator together with the units. The difference values between the forward and reverse flow rate totalized values can be displayed. The reverse flow rate is not counted for a forward single range.

Damping Time Constant:

Time constant can be set from 0.1 second to 200.0 seconds (63% response).

Span Setting Function:

Span flows can be set in units such as volume flow rate, mass flow rate, time, or flow rate value. The velocity unit can also be set.

Volume Flow Rate Unit: kcf, cf, mcf, Mgal (US), kgal (US), gal (US), mgal (US), kbbbl (US)*, bbl (US)*, mbbl (US)*, μ bbl (US)*, Ml (megaliter), m³, kl (kiloliter), l (liter), cm³

Mass Flow Rate Unit (Density must be set.): klb (US), lb (US), t (ton), kg, g

Velocity Unit: ft, m (meter)

Time Unit: s (sec), min, h (hour), d (day)

* "US Oil" or "US Beer" can be selected

Pulse Output:

Scaled pulse can be output by setting a pulse weight.

Pulse Width: Duty 50% or fixed pulse width (0.05, 0.1, 0.5, 1, 20, 33, 50, 100 ms) can be selected.

Output Rate: 0.0001 to 10,000 pps (pulse/second)

Multi-range Function:

Status input enables the switching of up to two ranges.

For automatic range switching, the status of up to four ranges can be shown via status outputs and on the indicator.

Forward and Reverse Flow Measurement Functions:

Flows in both forward and reverse directions can be measured. The status is shown via status outputs and on the indicator during the reverse flow measurement.

Totalization Switch:

If a totalized value becomes equal to or greater than the set value, a status output is generated.

Preset Totalization:

A parameter setting or status input enables a totalized value to be reset to a preset value or zero.

0% Signal Lock:

Status input fixes the instantaneous flow rate display, current output, pulse output, and flow rate totalization to 0%.

Alarm Selection Function:

Alarms are classified into System Alarms (hard failures), Process Alarms (such as 'Empty Pipe', 'Signal Overflow' and 'Coating Alarm'), Setting Alarms, and Warnings.

Whether alarms should be generated or not can be selected for each item. The current output generated for an alarm can be selected from among 2.4 mA or less, fixed to 4 mA, 21.6 mA or more, or HOLD.

Alarm Output:

Alarms are generated only for the items selected via the 'Alarm Selection Function' if relevant failures occur.

Self Diagnostics Functions:

If alarms are generated, details of the System Alarms, Process Alarms, Setting Alarms and Warnings are displayed together with descriptions of countermeasures.

Flow Upper/Lower Limit Alarms:

If a flow rate is greater or smaller than the set value, this alarm is generated. In addition, two upper limits (H, HH) and two lower limits (L, LL) can be set.

If a flow rate is greater or smaller than any of the set values, the status is output.

Electrode Coating Diagnostics Function:

This function enables monitoring of the coating of insulating substances on the electrodes. Depending on the status, users are notified by a warning or an alarm via status outputs. If replaceable electrodes are used, they can be removed and cleaned if coating occurs.

HAZARDOUS AREA CLASSIFICATION

FM:

Explosion proof for Class I, Division 1, Groups A, B, C & D.
 Dust-ignition proof for Class II/III, Division 1, Groups E, F & G.
 "SEAL ALL CONDUITS WITHIN 18 INCHES"
 "WHEN INSTALLED IN DIV. 2, SEALS NOT REQUIRED"
 Excitation Circuit: 140V max
 Enclosure: NEMA 4X
 Temp. Code: T6
 Ambient Temp.: -40°C to +60°C (-40°F to +140°F)
 Note: Installation shall be in accordance with the manufacturer's instructions and National Electric code, ANSI/NFPA-70.

CSA:

For CSA C22.2 Series

Explosion proof for Class I, Division 1, Group A, B, C, & D.
 Dust-ignition proof for Class II/III, Division 1, Group E, F & G.
 "SEAL ALL CONDUITS WITHIN 50 cm OF THE ENCLOSURE"
 "WHEN INSTALLED IN DIV. 2, SEALS NOT REQUIRED"

For CSA E79 Series

Flame proof for Zone 1, Ex d IIC T6

Excitation Circuit: 140V max
 Enclosure: Type 4X, IP66, IP67
 Temp. Code: T6
 Ambient Temp.: -40°C to +60°C (-40°F to +140°F)

STANDARD PERFORMANCE

Reference Conditions:

- Similar to BS EN 29104 (1993); ISO9104 (1991)
- Fluid temperature: +10°C to +30°C (+50°F to +86°F)
- Ambient temperature: +20°C to +30°C (+68°F to +86°F)
- Warm-up time: 30 min
- Straight runs
 - Upstream > 10 × DN
 - Downstream > 5 × DN
- Properly grounded
- Properly centered

Accuracy (Combined with AXF Remote Flowtube at reference conditions)

Pulse Output:

PFA/Ceramics Lining:

Size mm (in.)	Flow Velocity V m/s (ft/s)	Standard Accuracy (Calibration code B)	Flow Velocity V m/s (ft/s)	High grade Accuracy (Calibration code C)
2.5 (0.1) to 15 (0.5)	$V < 0.3$ (1)	1.0 mm/s	—	—
	$0.3 \leq V \leq 10$ (1) (33)	0.35% of Rate		
25 (1.0) to 200 (8.0)	$V < 0.15$ (0.5)	0.5 mm/s	$V < 0.15$ (0.5)	0.5 mm/s
	$0.15 \leq V \leq 10$ (0.5) (33)	0.35% of Rate	$0.15 \leq V < 1$ (0.5) (3.3)	0.18% of Rate + 0.2mm/s
			$1 \leq V \leq 10$ (3.3) (33)	0.2% of Rate
250 (10) to 400 (16)	$V < 0.15$ (0.5)	0.5 mm/s	—	—
	$0.15 \leq V \leq 10$ (0.5) (33)	0.35% of Rate		

T01.EPS

Enhanced dual frequency excitation (Option code HF2): Standard accuracy + 1 mm/ s

Size 2.5 mm (0.1 in.) to 15 mm (0.5 in.)

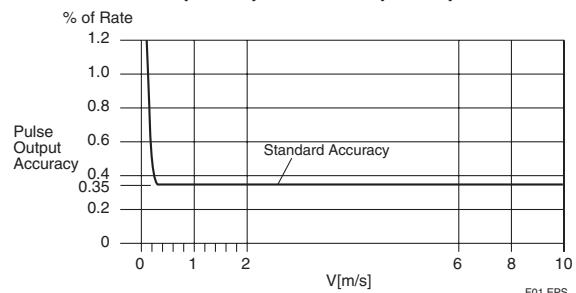

F01.EPS

Size 25 mm (1.0 in.) to 400 mm (16 in.)

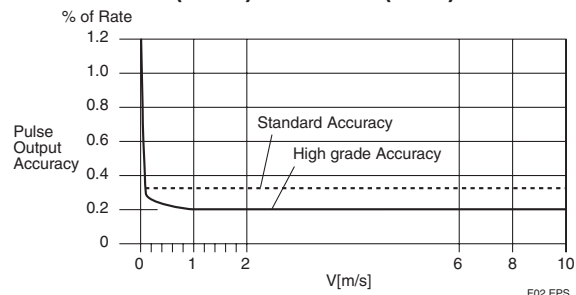

F02.EPS

Polyurethane Lining

Size mm (in.)	Flow Velocity V m/s (ft/s)	Standard Accuracy (Calibration code B)
25 (1.0) to 400 (16)	$V < 0.3$ (1.0)	1.0 mm/s
	$0.3 \leq V \leq 10$ (1.0) (33)	0.35% of Rate

T02.EPS

Enhanced dual frequency excitation (Option code HF2): Standard accuracy + 1 mm/ s

Size 25 mm (1.0 in.) to 400 mm (16 in.)

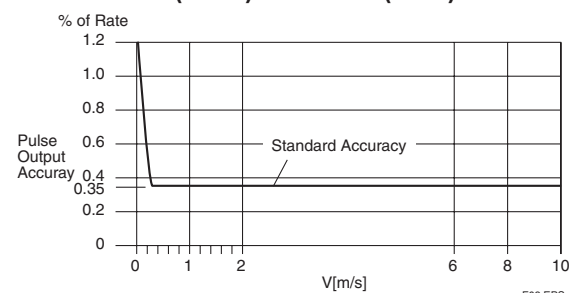

F03.EPS

Enhanced dual frequency excitation (Combined with AXF Remote Flowtube Optional code HF2):

Standard Accuracy +1 mm/s

Current Output: Plus 0.05% of Span

Repeatability:

0.1% of Rate ($V \geq 1$ m/s (3.3 ft/s))

0.05% of Rate + 0.5 mm/s ($V < 1$ m/s (3.3 ft/s))

Maximum Power Consumption:

Combined with AXF Remote Flowtube: 12 W

Insulation Resistance (*1):

100 MΩ between power terminals and ground terminal at 500 V DC

100 MΩ between power terminals and each output/status input terminal at 500 V DC

20 MΩ between ground terminal and each output/status input terminal at 100 V DC

20 MΩ between output/status input terminals at 100 V DC

Withstand Voltage (*1):

1350 V AC between power terminals and ground terminal for two seconds

160 V AC between excitation terminals and ground terminal for two seconds

200 V AC between excitation terminals and each output/status input terminal for two seconds



CAUTION

*1: Before performing the Insulation Resistance Test or the Voltage Breakdown Test, disconnect the ground terminal if the power terminal has a lightning protector (option code A). Following the relevant test, wait for more than 10 seconds after the power supply has been turned off before removing the cover. After testing, be sure to use a resistance for discharge and return the short bar to its correct position. Screws must be tightened to a torque of 1.18 N-m or more. After closing the cover, the power supply can be restored.

Safety Requirement Standards:

EN61010

- Altitude at installation site: Max. 2000 m above sea level
- Installation category based on IEC1010: Overvoltage category II ("II" applies to electrical equipment which is supplied from a fixed installation-like distribution board.)
- Pollution degree based on IEC1010: Pollution degree 2 ("Pollution degree" describes the degree to which a solid, liquid, or gas which deteriorates dielectric strength or surface resistivity is adhering. "2" applies to a normal indoor atmosphere.)

EMC Conformity Standards:

EN61326

EN61000-3-2, EN61000-3-3

AS/NZS 2064

■ NORMAL OPERATING CONDITIONS

Ambient Temperature: -40°C to +60°C (-40°F to +140°F)

- Indicator's operating range: -20°C to +60°C (-4°F to +140°F)
- Maximum temperature is 50°C for Power Supply Code 2.

Ambient Humidity: 0 to 100%

Lengthy continuous operation at 95% or more is not recommended.

Power Supply

Power supply code 1:

- AC specifications
Rated power supply: 100 to 240 V AC, 50/60 Hz
(Operating voltage range: 80 to 264 V AC)
- DC specifications
Rated power supply: 100 to 120 V DC
(Operating voltage range: 90 to 130 V DC)

Power supply code 2:

- AC specifications
Rated power supply: 24 V AC, 50/60 Hz
(Operating voltage range: 20.4 to 28.8 V AC)
- DC specifications
Rated power supply: 24 V DC
(Operating voltage range: 20.4 to 28.8 V DC)

Supplied Power and Cable Length for Power Supply Code 2

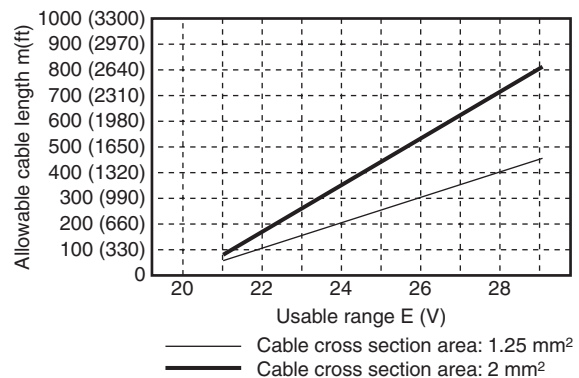

F04.EPS

Vibration Conditions:

Level of vibration in conformity with IEC 60068-2-6 (SAMA31. 1-1980)

1 G or less (frequency 500 Hz or less)

Note: Avoid locations with much vibration (with a vibration frequency of 500 Hz or more), which may cause damage to the equipment.

■ ACCESSORIES

Fuse (T2.0A, 250 V): 1 pc.

*Time lag fuse

Mounting bracket: 1 set

Hexagonal wrench: 1 pc.

MODEL AND SUFFIX CODE

AXFA14 Magnetic Flowmeter Remote Converter:

Model	Suffix Code	Description
AXFA14		Magnetic Flowmeter Remote Converter
Use	C	Explosion proof type For Remote Flowtube of Size 2.5 to 400 mm (0.1 in. to 16 in.)
Output Signal and Communication	-D	4 to 20 mA DC, BRAIN Communication
	-E	4 to 20 mA DC, HART Communication
Power Supply	1	100 V to 240 V AC or 100 to 120 V DC
	2	24 V AC/DC
Electrical Connections	-2	ANSI 1/2 NPT female
Indicator (*1)	1	With Indicator (Horizontal)
	2	With Indicator (Vertical)
	N	None
Option	/	Optional code (See the Table of Optional Specifications)

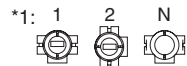

T03.EPS

Terminal Configuration

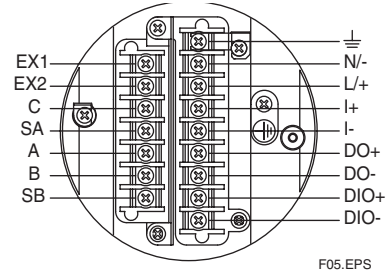

F05.EPS

Terminal Wiring

Terminal Symbols	Description	Terminal Symbols	Description
EX1 EX2	Excitation current Output	Functional grounding	Power supply
C SA A B SB		Flow signal input	
			I+ I-
		DO+ DO-	Pulse output/ Alarm output/ Status output
		DIO+ DIO-	Alarm output/ Status output/ Status input
		Protective grounding (Outside of the terminal)	

T06.EPS

Signal Cable: Model AXFC

Note:

- The cable is constructed with double shielding over the two conductors, and uses heat-resistant vinyl as the outer covering material.
Finished diameter: 10.5 mm (0.41 in.)
Maximum temperature: +80°C (+175°F)
- Not necessary to order the above cable for submersible type flowtube because the flowtube is wired with 30 m (98 ft) cable.
- Excitation cable is supplied by the customer.

Recommended Excitation, Power and Output Cable:

Use polyvinyl chloride insulated and sheathed control cable or Polyvinyl chloride insulated and sheathed portable power cables.

- Outer Diameter: 6.5 to 12 mm (0.26 to 0.47 in.)
- Nominal Cross Section: 0.5 to 2.5 mm²

■ OPTIONAL SPECIFICATIONS FOR AXFA14 REMOTE CONVERTER

o : Available –: Not available

Item	Specification	General-Purpose use	Explosion proof type	Code
Lightning Protector	A lightning protector is built into the power terminals.	o	o	A
Burn Out Down	The output level is set to 0 mA during a CPU failure and is set 2.4 mA or less during an alarm. Standard products are delivered with a setting 25 mA during a CPU failure and 21.6 mA or more during an alarm.	o	o	C1
NAMUR NE43 Compliance	Output signal limits: 3.8 to 20.5 mA	o	o	C2
	Failure alarm down-scale: The output level is set to 0 mA during a CPU failure and is set 2.4 mA (-10%) or less during an alarm. Failure alarm up-scale: The output level is set to 25 mA during a CPU failure and is set 21.6 mA (110%) or more during an alarm.	o	o	C3
Active Pulse Output	Active pulses are output in order to drive an external electromagnetic or electronic counter directly using the converter's internal power supply. (Nullifies the standard transistor contact pulse output.) Output voltage: 24 V DC \pm 20% Pulse specifications: • At the drive current of 30 to 150 mA Pulse rate: 0.0001 to 2 pps (pulse/second); Pulse width: 20, 33, 50, or 100 ms	o	o	EM
Stainless Steel Mounting Bracket	Provided with a JIS SUS304 (AISI 304 SS/EN 1.4301 equivalent) stainless steel mounting bracket in lieu of the standard carbon steel bracket.	o	o	SB
Stainless Steel Tag Plate	Screwed JIS SUS304 (AISI 304 SS/EN 1.4301 equivalent) stainless steel tag plate. Choose this option when an SS tag plate is required in addition to the standard nameplate with the tag number inscribed on it.	o	o	SCT
Epoxy Resin Coating	Epoxy resin coating instead of standard polyurethane resin coating. The color is same as standard type.	o	o	X1
FM Approval	Explosion proof See "HAZARDOUS AREA CLASSIFICATION"	–	o	FF1
CSA Certification	Explosion proof See "HAZARDOUS AREA CLASSIFICATION"	–	o	CF1
CSA Mark	CSA Mark for General Purpose AXF converters and flow tubes	o	–	CGP

T05.EPS

EXTERNAL DIMENSIONS

Remote Converter AXFA14

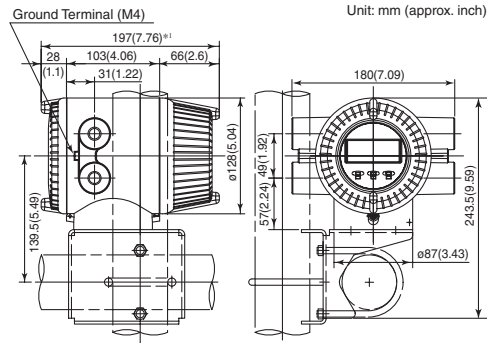

Weight: 2.8kg (6.2lb)

*1: When indicator code N is selected, subtract 12 mm (0.47 inch) from the value in the figure.
For explosion proof type with indicator, add 5 mm (0.2 inch) to it.

F06.EPS

Dedicated Signal Cable

AXFC-4-L□□□

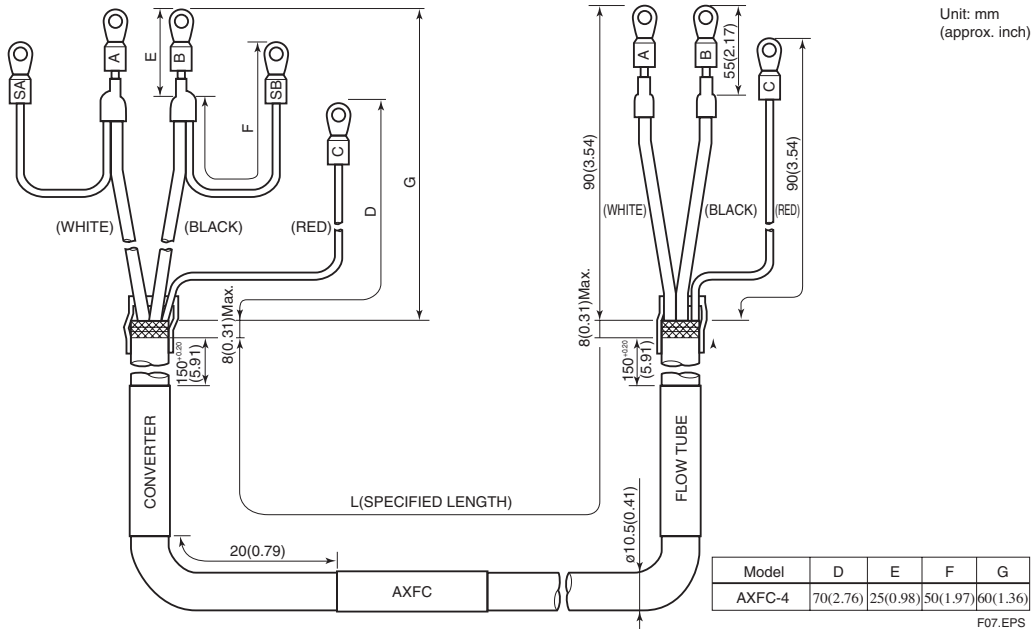

AXFC-0-L□□□

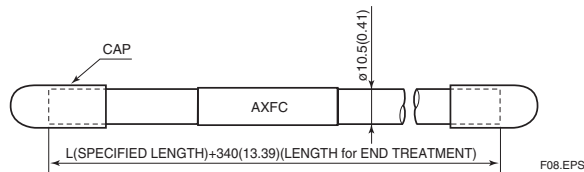

ORDERING INFORMATION

Note 1: When ordering a remote flowtube and/or a remote converter, specify the flow span, unit, pulse weight, and totalizer display pulse weight.

These parameters will then be set in the combined converter before shipment.

Note 2: Some options, if ordered, require the relevant specifications be supplied.

1. Model, specification and option codes.
2. Tag number.

Each tag number can be specified up to 16 characters in a combination of letters (upper or lower case), numbers, “-” and “.”. If specified, the tag number is inscribed on the product’s name plate and tag plate (if optional code SCT is selected). For HART protocol, up to 8 characters can be specified.