

General Specifications

Model RAMC Metal Short-stroke Rotameter

A float is guided concentrically to a special shaped conic metal tube. The position of this float is magnetically transmitted to the indicator. The short-tube Rotameter is used for measurement of flow rates of liquids and gases. Its special application is in troubled, opaque or aggressive mediums. The instrument is mounted in a vertical pipeline with flow direction upwards.

The indicators are exchangeable without influence on the accuracy.

FEATURES

- Different process connections like flanges according EN and ASME
- All wetted parts in stainless steel or PTFE
- Maximum flow 0.025 - 130 m³/h water resp. 0.75 - 1400 m³/h air (20 °C / 1.013 bar abs)
- Accuracy class 1.6 resp. 2.5 with lining acc. VDI/VDE 3513
- Float damping to avoid float bouncing with gas applications
- Optional heat tracing (with steam or fluid heat carrier)
- Indicator in stainless steel, aluminium or plastic, protection class IP65 or IP66/67
- Local indicator without additional power supply
- Microprocessor controlled transmitter with 24 V, 115 V or 230 V power supply
- Intrinsically safe version (Ex-i) (ATEX, FM/CSA, SAA, NEPSI)
- Flame proof version (Ex-d) (ATEX)
- Dust explosion proof (ATEX)
- Suitable for SIL application, SIL report on request
- Limit switches, also available as "Fail Safe" version

Electronic transmitter as standard with local-controlling display with the following features :

- Flow indication (totalize, actual, percent)
- Indication of different volume- and massflow units
- Second (manual) calibration storing
- Patented float blocking indication function
- Signal output damping
- Error message indication
- Temperature measurement in the electronic transmitter
- HART- communication
- Profibus PA - communication



CONTENTS

Features	page 1
Standard Specification	page 2
Hazardous Area Specifications	page 4
Installation	page 7
Model Specifications	page 11
Options	page 12
Process connection table for metal tubes	page 13
Flow tables for metal tubes	page 14
Process connection and flow table for tubes with PTFE lining..	page 15
Temperature graphs	page 16
Dimensions and weights	page 17

STANDARD SPECIFICATIONS

METERING TUBES

Materials of wetted parts :

- Stainless steel AISI 316L (1.4404)
- PTFE
- other materials on request

Fluids to be measured :

suitable for a variety of liquids, gas and steam

Measuring range :

see table 13 and 14

Measuring range ratio :

10:1

Process connections / Stainless steel :

- Flanges :
 - acc. EN1092-1
 - DN100 – DN150 PN16
 - DN15 – DN100 PN40
 - DN50 – DN80 PN63
 - DN15 – DN50 PN100
 - acc. ASME B 16.5
 - ½" – 6" Class 150 raised face
 - ½" – 6" Class 300 raised face
 - ½" – 3" Class 600 raised face
 - Roughness of sealing
 - Form B1 : RA 3.2 - 6.3
 - Form B2 : RA 0.8 - 3.2
 - ASME : RA 3.2 - 6.3
- Threaded connection :
 - male acc. DIN 11851
 - NPT-female
 - G-female
 - Clamp acc. DN25 / 1" – DN100 / 4"

Process pressure :

depends on process connection, see table 12 to 14
higher pressure (up to 700 bar) on request

Process temperature :

- medium wetted parts made of stainless steel
 - : -180 ... +370 °C
- medium wetted parts made of PTFE
 - : -80 ... +130 °C

Accuracy class :

Table 1

Material of wetted parts	Size	Accuracy class acc. VDE/VDI 3513 edition 12/1978	Standard flow accuracy: full scale
SS	DN 15 - 100	1.6	± 1.6%
SS	DN 125 - 150	2.5	± 2.5%
PTFE	DN 15 - 100	2.5	± 2.5%

TO.EPS

Pressure Equipment Directive (PED) Directive 97/23/EG :

- Tubes :
- Modul : H
 - Fluid Group : 1 (dangerous fluids)
 - Produced acc. to category : III
 - Classification : Table 6 (piping)

Heating (options /T1 to /T6) :

- Art. 3 section 3 : (Volume < 1L)
- Fluid Group : 2 (non-dangerous fluids)
- Classification : Table 2 (vessels)

Installation :

- Mounting direction : vertical
- Flow direction : upwards
- Mounting length : see tables 12 to 15
- Straight pipe inlet length : DN 80/100 at least 5D, not necessary for smaller sizes

Weight :

see table 18

LOCAL INDICATOR

(Indicator/Transmitter Code -T)

Principle :

The indication is made by magnetic coupling of a magnet enclosed in the float and a magnet in the indication unit, which follows the movements of the float.

Indicator housing :

- Materials :
 - Stainless steel (1.4301)
 - painted aluminium casting
 - painted Polyamid with fiberglass each with safety-glass window
- Degree of protection :
 - IP65 (housing type 66 and 90)
 - IP66/67 (housing type 91)

Scales :

- Standard : removable aluminium plate with scale (double scale as option)
- Marking : direct readable units or percentage of Q_{max}

Transportation- and Storage condition :

-40°C to +110°C

Process-/ Ambient temperature :

see fig. 6a to 6d

ELECTRONIC TRANSMITTER

(Indicator/Transmitter Code -E, -H, -G)

Standard type (Code -E) :

Power supply :

- 4-wire units with galvanic isolation :
 - 230 V AC +10 %/-15 %, 50/60 Hz, fuse 0.063 A, time lag, (5x20) mm
 - 115 V AC +10 %/-15 %, 50/60 Hz, fuse 0.125 A, time lag, (5x20) mm
- 2/3-wire units : - U = 13.5 V... 30 V DC

Output signal :

- 4-wire units :
 - 0 - 20 mA, 4 - 20 mA
 - pulse output (option /CP) max. frequency 4 Hz see fig. 3
- 3-wire units : 0 - 20 mA, 4 - 20 mA
- 2-wire units : 4 - 20 mA

The 20mA point is selectable between 60% and 100% of Q_{nom} .

Load resistance :

- 4-wire units : $\leq 500 \Omega$
- 2/3-wire unit : $\leq (U-13.5 V)/20 \text{ mA}$

HART- communication type (Code -H) :

Power supply :

- 2-wire units : - U = 13.5 V... 30 V DC

Output signal :

- 2-wire units : 4 - 20 mA

Load resistance :

- HART-version : 250 ... 500 Ω

Profibus PA - communication type (Code -G) :

- 2-wire bus connection not polarity sensitive : 9 ... 32V DC acc. to IEC 61568-2 and FISCO model
- Basic current : 14 mA
- Failure current (FDE) : 10mA additional to basic current
- Transmission rate : 31.25 kBaud
- AI block for volume flow or mass flow
- Configurable with PDM DD
- Supports I&M-functions

Digital display :

8-digits 7-segment-LC-display character height 6 mm

Process-/ Ambient temperature :

The dependency of the process temperature from the ambient temperature is shown in fig. 6a to fig. 6d.

The internal temperature of the electronic transmitter can be indicated on the display or checked via HART communication.

Measurement of the internal transmitter temperature :

- Range : -25 °C to +70 °C
- Accuracy : ±5 °C

Transportation- and Storage condition :

-40 °C to +70 °C

Linearity :

± 0.2 % f.s.

Hysteresis ¹⁾ :

± 0.1 % f.s.

Repeatability ¹⁾ :

± 0.1 % f.s.

Influence of power supply ¹⁾ :

± 0.1 % f.s.

Temperature coefficient of the output signal ¹⁾ :

± 0.5 %/10 K f.s.

AC-part of output signal ¹⁾ :

± 0.15 % f.s.

Long-time stability ¹⁾ :

± 0.2 % /year

Max. output signal :

21.5 mA

Output signal in case of failure :

≤ 3.6 mA (acc. NE 43)

Response time (99%) :

About 1.5 s (damping 1s)

Electromagnetic compatibility (EMC) :

- Emission acc. EN 55011: 2003 : class A, group 1
- EN 61000-3-2 : 2001
- EN 61000-3-3 : 2002
- Immunity acc. EN 61326 : 2002 :
Criterion A, restriction :HF-immunity between 500 MHz and 750 MHz : criterion B

Unit safety acc. DIN EN61010-1 : 2002

- Overvoltage category : II (acc. VDE 0110 or IEC 664)
- Pollution degree : I
- Safety class : I (with 115 / 230V AC power supply)
III (with 24V DC power supply and
Fieldbus type)

POWER SUPPLY FOR ELECTRONIC TRANSMITTER

(Option /U__)

Type :

power supply with galvanically separated input and output
- SINEAX B811, HART- compatible type available

Supply voltage :

- 24 V to 60 V AC/DC
- 85 V to 230 V AC

Maximum load :

750 Ω

Output signal :

0/4 mA - 20 mA

CABLE GLAND (for transmitter -E, -H and -G) :**Size :**

- M16x1.5 (standard)
- Thread M20x1.5 (option /A13; standard for option /KF1)
- Thread ½" NPT (option /A5)

Cable diameter :

6–9 mm

Maximum cross section of core :

Ø 1.5 mm²

LIMIT SWITCHES IN STANDARD VERSION

(option /K1 to /K3)

Type :

Inductive proximity switch S 3.5-NO acc. DIN EN 60947-5-6

Nominal voltage :

8VDC

Output signal :

≤ 1 mA or ≥ 3 mA

LIMIT SWITCHES IN FAIL SAFE VERSION

(option /K6 to /K10)

Type :

Inductive proximity switch SJ3.5-SN; SJ3.5-S1N
acc. DIN EN 60947-5-6 (NAMUR)

Nominal voltage :

8VDC

Output signal :

≤ 1 mA or ≥ 3 mA

HYSTERESIS OF LIMIT SWITCHES**Min-contact :**

- pointer movement : ≈ 0.5 mm
- float movement : ≈ 0.8 mm

Max-contact :

- pointer movement : ≈ 0.5 mm
- float movement : ≈ 0.6 mm

CABLE GLAND (option /K1 to /K10)**Size :**

- M16x1.5 (standard)
- Thread M20x1.5 (option /A13; standard for option /KF1)
- Thread ½" NPT (option /A5)

Cable diameter :

6–9 mm

Maximum cross section of core :

Ø 1.5 mm²

¹⁾ referenced to 20°C ambient temperature

POWER SUPPLY FOR LIMIT SWITCHES

(Option /W___)

Type :

- Transmitter relay acc. DIN EN 50227 (NAMUR)
- KFA6-SR2-Ex1.W (230 V AC)
- KFA5-SR2-Ex1.W (115 V AC)
- KFD2-SR2-Ex1.W (24 V DC)

Power supply :

- 230 V AC \pm 10%, 45-65Hz
- 115 V AC \pm 10%, 45-65Hz
- 24 V DC \pm 25%

Relay output :

- 1 or 2 potential-free changeover contact(s)

Switching capacity :

max. 250V AC, max. 2 A

SWITCHING LEVELS FOR LIMIT SWITCHES

Table 2 Limit switch as Min, Max and Min-Max-contact in standard and fail-safe version.

Function	Pointer	SC 3,5-N0		SJ 3,5-SN		
		Switch	Signal	Switch	Signal	Fail safe
MAX	above LV	on	1mA	on	1mA	1mA
	below LV	off	3mA	off	3mA	
MIN	above LV	off	3mA	off	3mA	1mA
	below LV	on	1mA	on	1mA	

Note : LV = Limit value

T2.EPS

Table 3 Limit switch as Min-Min-contact in standard and fail-safe version.

Function	Pointer	SJ 3,5-SN		SJ 3,5-S1N		
		Switch	Signal	Switch	Signal	Fail safe
upper MIN	above LV	----	----	off	3mA	1mA
	below LV	----	----	on	1mA	
lower MIN	above LV	off	3mA	----	----	1mA
	below LV	on	1mA	----	----	

Note : LV = Limit value

T3.EPS

Table 4 Limit switch as Max-Max-contact in standard and fail-safe version.

Function	Pointer	SJ 3,5-SN		SJ 3,5-S1N		
		Switch	Signal	Switch	Signal	Fail safe
upper MAX	above LV	on	1mA	----	----	1mA
	below LV	off	3mA	----	----	
lower MAX	above LV	----	----	on	1mA	1mA
	below LV	----	----	off	3mA	

Note : LV = Limit value

T4.EPS

Note :

If 2 Fail-Safe limit switches option /K6 ... /K10 are used in a RAMC also 2 power supplies option /W2E or /W4E are necessary.

HAZARDOUS AREA SPECIFICATIONS

INTRINSIC SAFETY

Attention :

The maximum ambient temperature of the transmitter or of the limit switches according to the temperature class may not be exceeded because of heat transmission from the medium.

Table 5 Entity parameters of electronic transmitter

	Ui [V]	Ii [mA]	Pi [W]	Ci [nF]	Li [mH]	Ta max [°C]
KS1/2	30	101	1.4	4.16	0.15	70
KN1	30	152	1.4	4.16	0.15	70
FS1	30	100	1.4	40	0.15	70
SS1	30	186	1.4	3.6	0.73	65*)
NS1	30	101	1.4	4.16	0.15	70

*) with limit switches : 40°C

T1.EPS

Intrinsically safe electronic transmitter 4 - 20mA (with/without HART-communication) with ATEX-certification (option /KS1) :

Certificate :

PTB 96 ATEX 2160X

Output signal :

4-20 mA (2-wire unit, 3-wire unit) ; 0-20mA (3-wire unit)

Explosion proof :

EEx ia IIC T6; group II ; category 2G

Entity parameter :

see table 5

Intrinsically safe electronic transmitter Profibus PA - communication with ATEX- certification (option /KS1) :

Certificate :

PTB 96 ATEX 2160X

Output signal :

Profibus PA

Explosion proof :

EEx ia IIB/IIC T4; group II ; category 2G

Table 6 Entity parameters

	IIC	IIB	FISCO IIB / IIC
Ui	24V	17.5V	acc. IEC 60079-27
Ii	250mA	280mA	
Pi	1.2W	4.9W	
Li	negligible	negligible	
Ci	negligible	negligible	

T28.EPS

Electronic transmitter 4 - 20mA (with/without HART-communication) type "n" (non incensive) acc. EN 60079-15 for category 3 (option /KN1) :

Output signal :

4-20 mA (2-wire unit, 3-wire unit) ; 0-20mA (3-wire unit)

Explosion proof :

EEx nL IIC T6 protection „nL“; group II ; category 3G

Dust proof :

EEx II 3D; group II ; category 3D
Max. surface temperature : 80°C

Entity parameter :

see table 5

Intrinsically safe electronic transmitter with FM - certification (USA + Canada) (option /FS1) :

Certificate :

No. : 3027471

Output signal :

4-20 mA (2-wire unit)

Explosion proof :

Intrinsic safe Cl. I, Div. 1, GP. A, B, C, D T6
Intrinsic safe Cl. 1, Zone 0, AEx ia IIC T6
Non incensive Cl. I, Div. 2, GP. A, B, C, D T6

Entity parameter of electronic transmitter :

see table 5

Intrinsically safe RAMC with NEPSI -certification (China) (option /NS1) :

Certificate :

GYJ05152

Output signal :

4-20 mA (2-wire unit, 3-wire unit) ; 0-20mA (3-wire unit)

Explosion proof :

Ex ia IIC T6

Max. Tamb. :

70°C

Entity parameter of electronic transmitter :

see table 5

Limit switches :

option /K1 to /K10

Entity parameter of limit switches :

see certificate NEPSI GYJ06542X

Intrinsically safe RAMC with SAA -certification (Australia) (option /SS1) :**Certificate :**

AUS Ex3777X

Output signal :

4–20 mA (2-wire unit)

Explosion proof :

Ex ia IIC T5

Max. Tamb. :

65°C (with limit switches 40°C)

Degree of protection :

IP54

Entity parameter of electronic transmitter :

see table 5

Limit switches :

option /K6 to /K10

Entity parameter of limit switches :

see certificate AUS Ex 02.3839X

Power Supply for the intrinsically safe electronic transmitter (option /U__)**Type :**

Intrinsically safe power supply with galvanically separated input and output
- SINEAX B811, HART- compatible type available

Certificate :

PTB 97 ATEX 2083

Supply voltage :

- 24 V to 60 V AC/DC
- 85 V to 230 V AC

Maximum load impedance :

750 Ω

Output signal :

0/4 mA - 20 mA

Control circuit :

Intrinsically safe [EEx ia] IIC group II, category (1)G

Entity parameters :

see fig 4

Intrinsically safe and dust proof limit switches with ATEX-certification (option /K1 .. /K10 with /KS1) :**Certificate :**

- PTB 99 ATEX 2219X (SC3.5-NO)
- PTB 00 ATEX 2049X (SJ 3.5-S.N)
- ZELM 03 ATEX 0128X (for dust proof)

Explosion proof :

EEx ia IIC T6, group II category 2G

Dust proof (only indicator "T") :

EEx iaD 20 T 108 °C, group II category 1D
Max. surface temperature : T108°C

Entity parameter :

see certificate of conformity

Limit switches for category 3 (option /K1 .. /K10 with /KN1) :**Explosion proof :**

EEx nL IIC T6 X protection „nL“; group II ; category 3G

Dust proof :

EEx II 3D; group II ; category 3D
Max. surface temperature : T112°C

Entity parameter :

see specification of SC3,5-NO Blue (P&F)* (/K1 ... /K3)
see specification of SJ3,5-SN (P&F)* (/K6 ... /K10)
see specification of SJ3,5-S1N (P&F)* (/K6 ... /K10)

* P&F = Pepperl & Fuchs

Intrinsically safe limit switches with CSA-certification (USA + Canada) (option /K1 .. /K10 with /FS1) :**Certificate :**

1007121 (LR 96321-2)

Explosion proof :

Cl. I, Div. 1, Grp A, B, C, D
Cl. II, Div. 1, Grp. E, F, G
Cl. III, Div. 1

or

Class I, Zone 0, Gp. IIC T6 (Ta = 60°C)

Entity parameter :

see FM-control drawing 116-0165b / 116-0155

Power supply for intrinsically safe limit switches (option W__):**Type :**

- KFA6-SR2-Ex1-W (230 V AC)
- KFA5-SR2-Ex1-W (115 V AC)
- KFD2-SR2-Ex1-W (24 V DC)

Certificate :

- PTB 00 ATEX 2081 (115/230 V AC)
- PTB 00 ATEX 2080 (24 V DC)

Control circuit :

[EEx ia] IIC; group II ; category (1)GD

Entity parameter :

see fig. 4

Intrinsically safe electronic transmitter 4 - 20mA, with/without limit switches with ATEX- certification gas- and dust proof (option /KS2) :**Certificate :**

PTB 96 ATEX 2160X (Intrinsic safe electronic transmitter)
PTB 99 ATEX 2219X (Intrinsic safe limit switch SC3.5-NO)
PTB 00 ATEX 2049X (Intrinsic safe limit switch SJ 3.5-S.N)
IBExU 05 ATEX 1086 (Dust proof)

Output signal electronic transmitter:

4–20 mA (2-wire unit, 3-wire unit) ; 0-20mA (3-wire unit),
Profibus PA

Explosion proof :

EEx ia IIC T6; group II ; category 2G (4-20mA unit)
EEx ia IIB/IIC T4; group II ; category 2G (Profibus PA unit)

Dust proof :

Group II ; category 1D
Max. surface temperature TX : corresponding process
temperature

Entity parameter :

see table 5 or 6 for electronic transmitter
see certificates for limit switches

Housing :

Painted aluminium casting, type 91

Ambient temperature :

-20 °C to 60 °C (category 2G / 2D)
-20 °C to 55 °C (category 1D)

Minimum process temperature :

-20°C

Threads for cable glands :

- M20x1.5 (standard)
- ½" NPT (option /A5)

FLAME PROOF AND DUST PROOF RAMC

Flame proof and dust proof RAMC with ATEX-certificate (option /KF1) :

Certificate :

IBExU 05 ATEX 1086

Flame proof :

EEx d IIC T1 ... T6 ; group II ; category 2G

Dust proof :

Group II ; category 1D

Max. surface temperature TX : corresponding process temperature

Housing :

Painted aluminium casting, type 91

Output signal :

4–20 mA (2-wire unit, 3-wire unit) ; 0-20mA (3-wire unit)

Power supply :

2- or 3- wire unit

Ambient temperature :

-20 °C to 60 °C (category 2G / 2D)

-20 °C to 55 °C (category 1D)

Minimum process temperature :

-20°C

Threads for cable glands :

- M20x1.5 (standard)

- ½" NPT (option /A5)

Temperature classification :

Table 7 For RAMC with limit switch

Temp. class	Max. ambient temperature [°C]	Max. process temperature [°C]
T6	60	85
T5	60	100
T4 ... T1	60	120

T1Ex.EPS

Table 8 For RAMC with electronic transmitter

Temp. class	Max. ambient temperature [°C]	Max. process temperature [°C]
T6	60	70
T5 ... T1	60 40	70 100

T2Ex.EPS

Table 9 For RAMC with limit switch with extension (option /A16)

Temp. class	Max. ambient temperature [°C]	Max. process temperature [°C]
T6	60	85
T5	60	100
T4	60	135
T3	60	200
T2	60	300
T1	60	370

T3Ex.EPS

Table 10 For RAMC with electronic transmitter with extension (option /A16)

Temp. class	Max. ambient temperature [°C]	Max. process temperature [°C]
T6	60	85
T5	60	100
T4	60	135
T3	60	200
T2 ... T1	60	300

T4Ex.EPS

Table 11 For RAMC with limit switch with extension (option /A16) and insulation (rock wool between tube and back side of indicator)

Temp. class	Max. ambient temperature [°C]	Max. process temperature [°C]
T6	60	85
T5	60	100
T4	60	135
T3	60	200
T2	60	300
T1	60	350

T5Ex.EPS

Table 12 For RAMC with electronic transmitter with extension (option /A16) and insulation (rock wool between tube and back side of indicator)

Temp. class	Max. ambient temperature [°C]	Max. process temperature [°C]
T6	60	85
T5	60	100
T4	60	135
T3	60 40	150 200
T2 ... T1	60 40	150 250

T6Ex.EPS

INSTALLATION

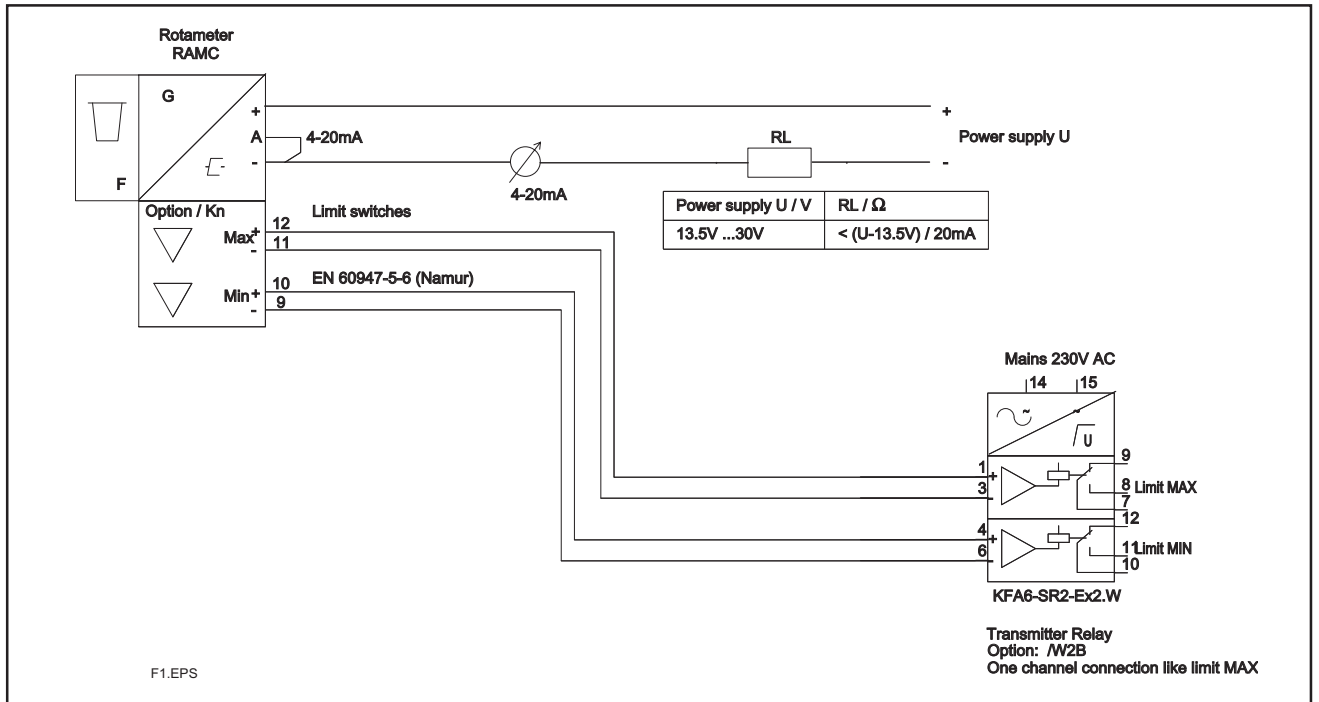

fig. 1 RAMC 2-wire unit with inductive limit switches and transmitter relay.

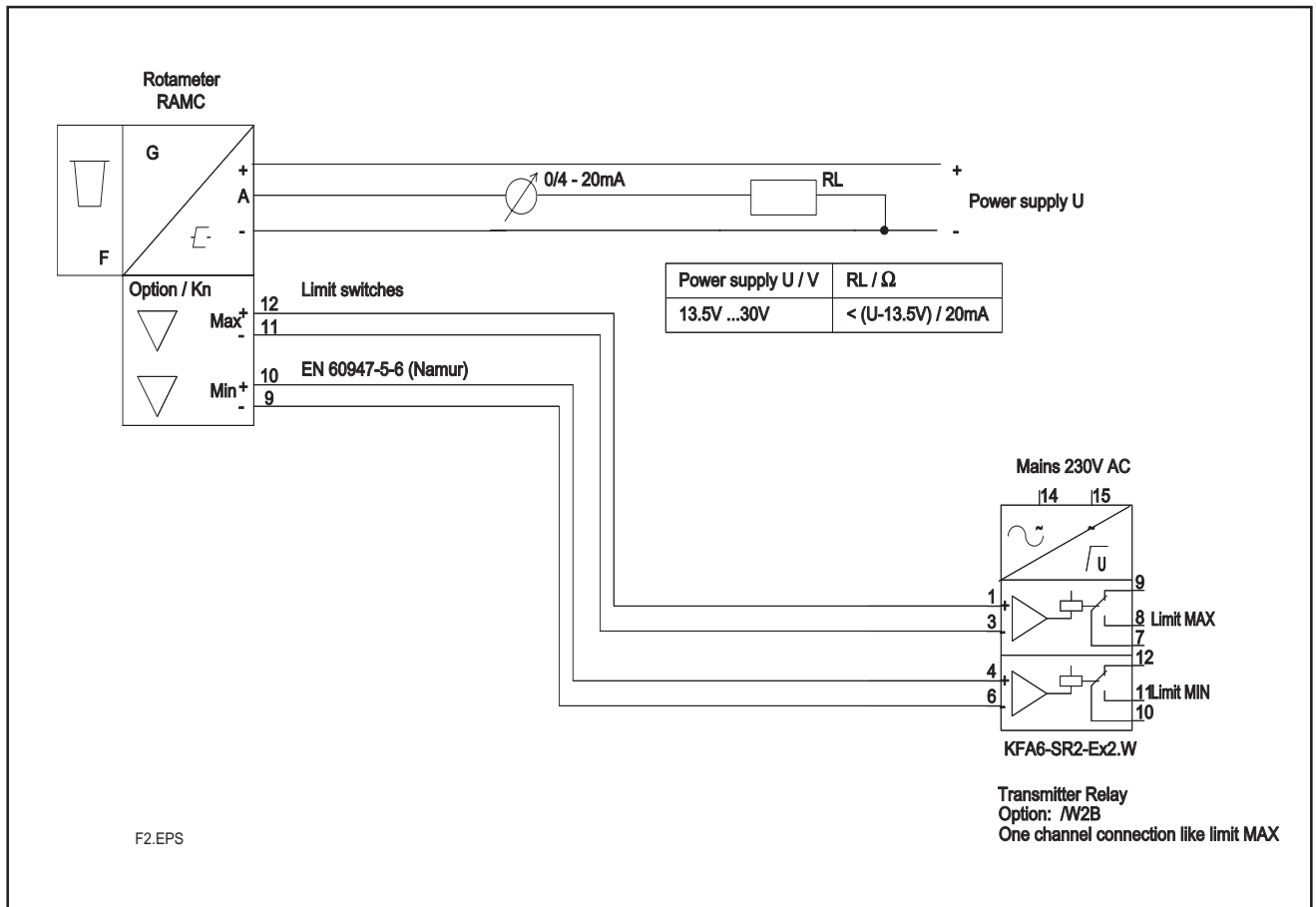

fig. 2 RAMC 3-wire unit with inductive limit switches and transmitter relay.

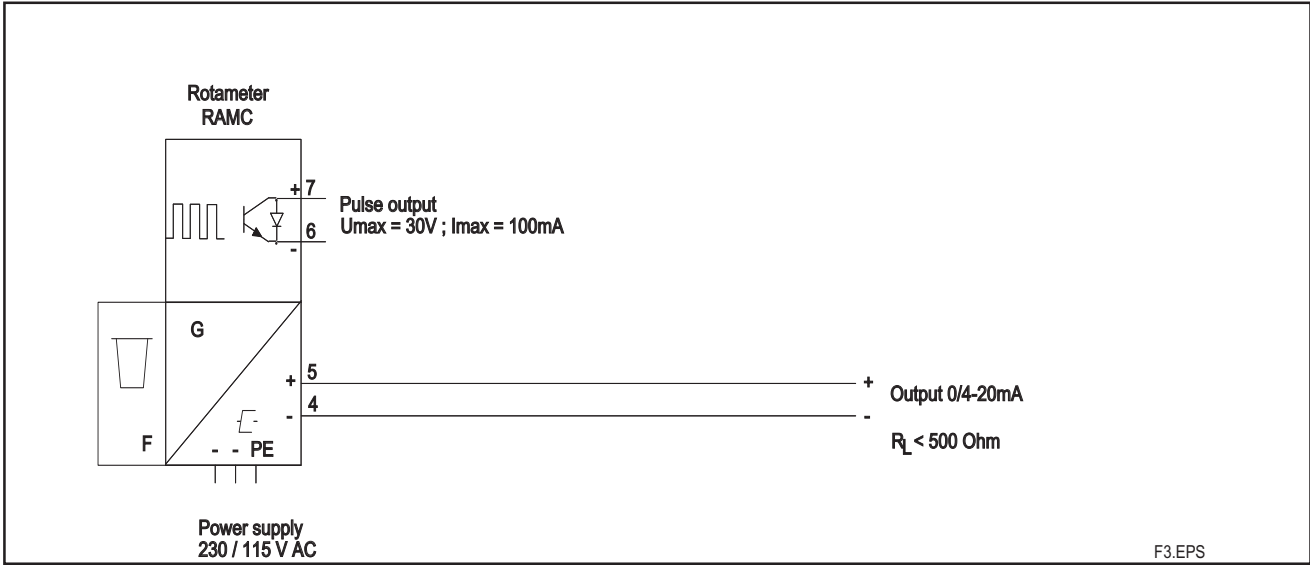

fig. 3 RAMC 4-wire unit with pulse output

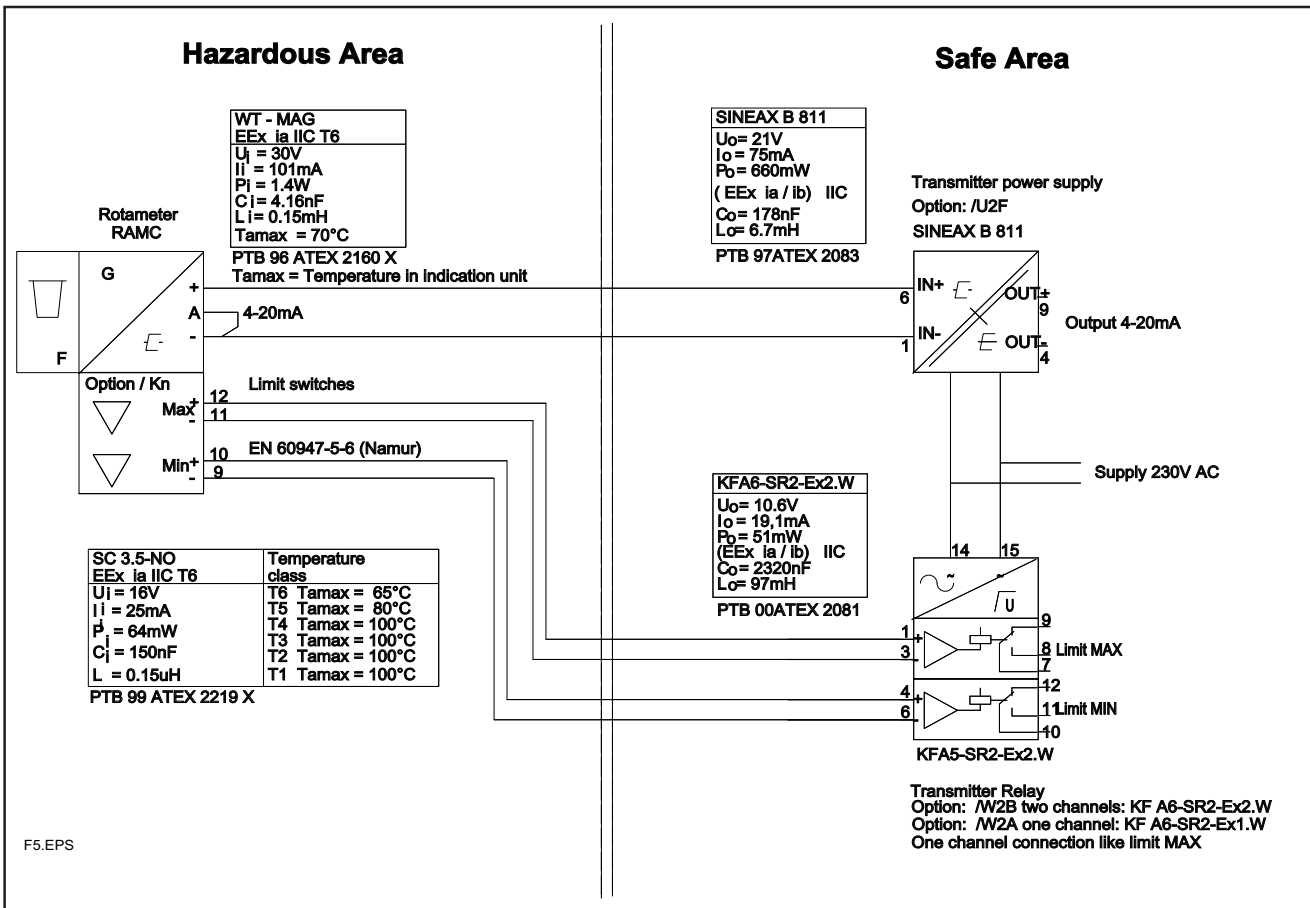

fig. 4 Intrinsic safe version according ATEX (option /KS1) : RAMC 2-wire unit with power supply, inductive limit switches and transmitter relay.

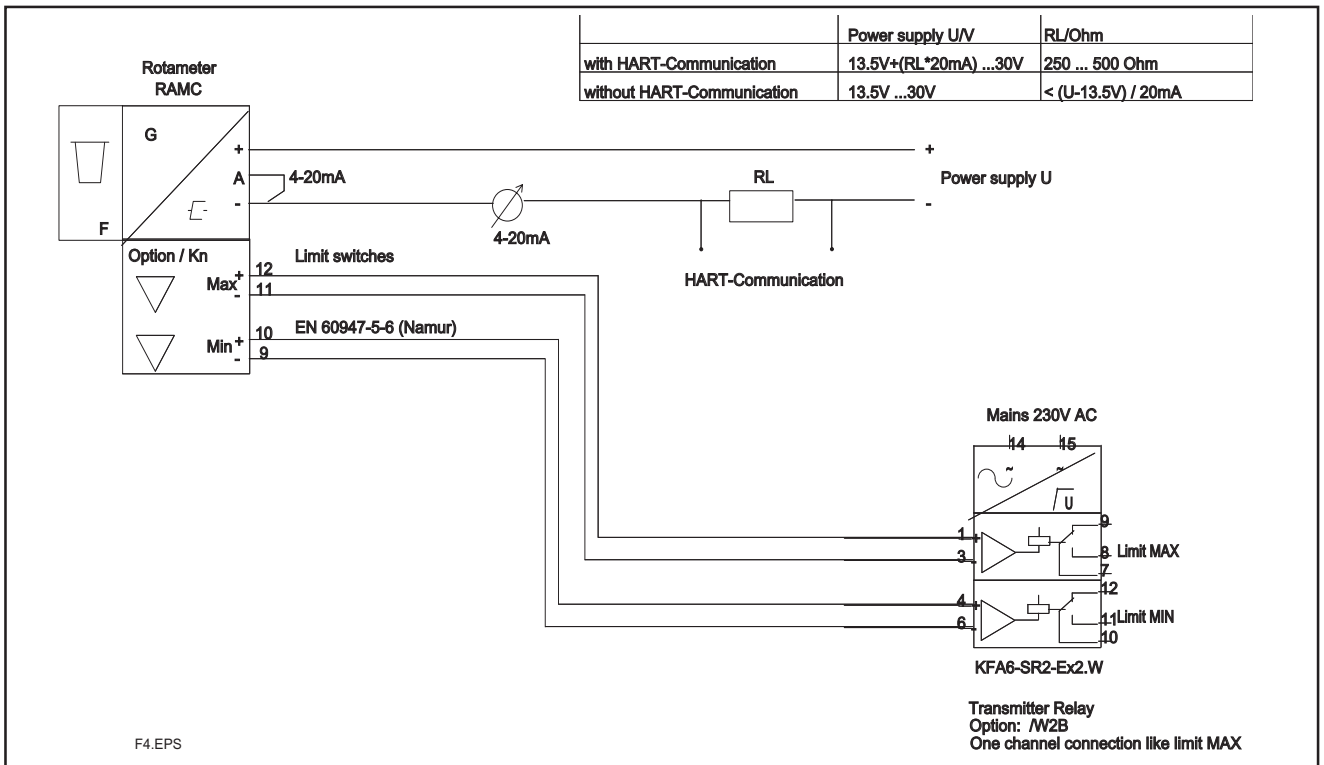

fig. 5 RAMC 2-wire unit with HART-communication, inductive limit switches and transmitter relay.

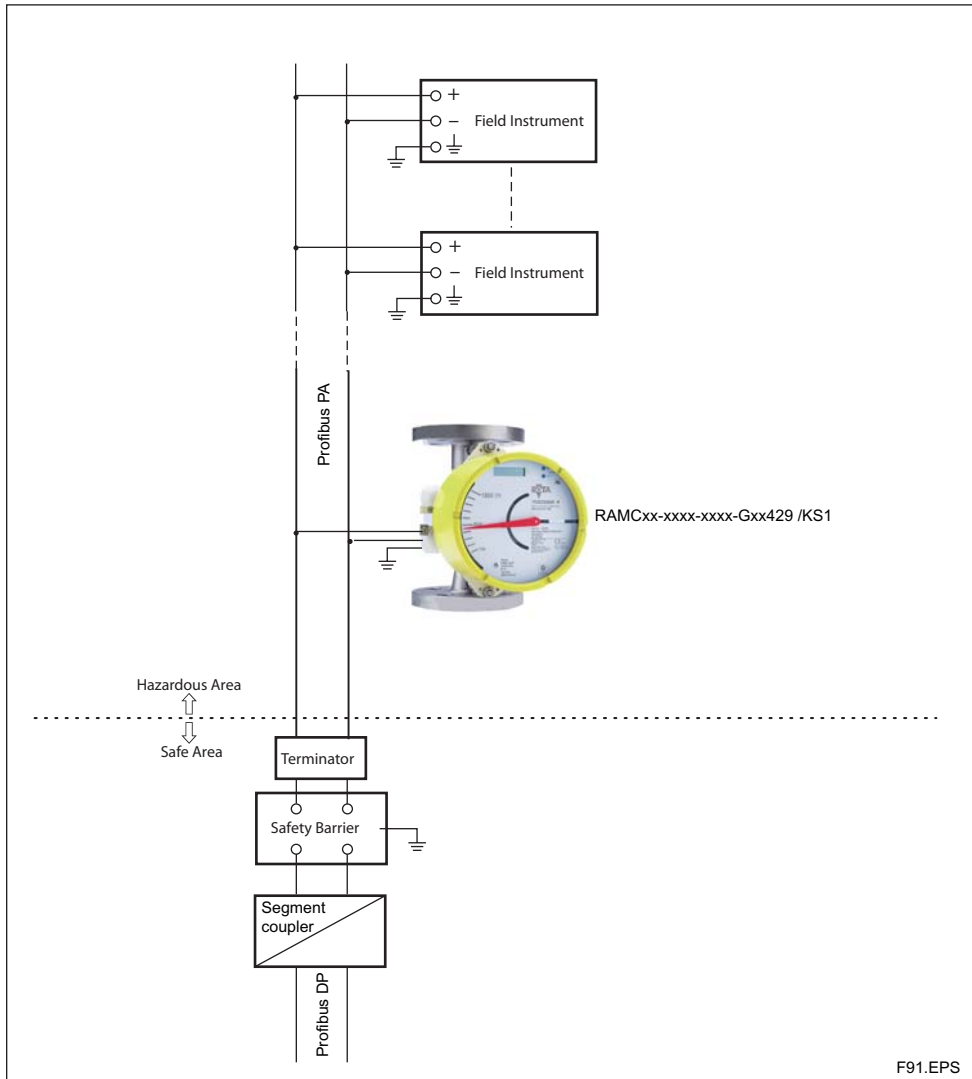

fig. 6 RAMC Profibus PA - communication

Planning and Installation Hints

- The user is responsible for the use of our flowmeters regarding suitability and use as agreed.
- The actual operation pressure must be lower as the specified pressure limits of the Rotameter.
- Make sure that the wetted parts are resistant against the process medium.
- Ambient- and process temperature must be lower than the specified maximum values.
- If dirt accumulation is to be expected, we recommend to install a bypass pipe
- To avoid float bouncing in case of gas application notice the recommendations of VDI/VDE 3513 Sheet 3.
- To avoid mutual magnetic influence in case of parallel design of several Rotameters take care that the distance between the tube middle axes is not less than 300 mm. The distance to other ferric materials should not be less than 250 mm.
- Avoid static magnetic fields next to the Rotameter.

MODEL SPECIFICATIONS

Model	Suffix code	Option code	Description	Restrictions
RAMC01	Size DN 15 (½ inch)	for D4, D6, A1, A2, A3, T4, R4, T6, G6
RAMC23	Size DN 20 (¾ inch)	for D4, D6, A1, A2, A3, T4, R4, T6, G6
RAMC02	Size DN 25 (1 inch)	for D4, D6, A1, A2, A3, S2, S4, S5, T4, R4, T6, G6
RAMC03	Size DN 32 (1 ¼ inch)	for D4, D6, A1, A2, A3, S4, T6, G6
RAMC04	Size DN 40 (1 ½ inch)	for D4, D6, A1, A2, A3, S4, S5, T6, G6
RAMC05	Size DN 50 (2 inch)	for D4, D5, D6, A1, A2, A3, S2, S4, T4, R4
RAMC06	Size DN 65 (2 ½ inch)	for D4, D5, A1, A2, A3, S2, S4, T4, R4, T6, G6
RAMC08	Size DN 80 (3 inch)	for D4, D5, A1, A2, A3, S2, S4
RAMC09	3 ½ inch	for A1, A2
RAMC10	Size DN 100 (4 inch)	for D2, D4, A1, A2, S2, S4
RAMC12	Size DN 125 (5 inch)	for D2, A1, A2, S2
RAMC15	Size DN 150 (6 inch)	for D2, A1, A2
RAMCNN	Without measuring tube	
Process connection	-D2	EN flange PN 16, process connection dimensions + facing acc. EN1092 - 1 Form B1	
	-D4	EN flange PN 40, process connection dimensions + facing acc. EN1092 - 1 Form B1	
	-D5	EN flange PN 63, process connection dimensions + facing acc. EN1092 - 1 Form B2	
	-D6	EN flange PN 100, process connection dimensions + facing acc. EN1092 - 1 Form B2	
	-A1	ASME flange class 150, process connection dimensions + facing acc. ASME B16.5	
	-A2	ASME flange class 300, process connection dimensions + facing acc. ASME B16.5	
	-A3	ASME flange class 600, process connection dimensions + facing acc. ASME B16.5	
	-T6	Thread female NPT - PN40	
	-G6	Thread female G : PN40	
	-R4	Thread female Rp : removable	
	-S2	Thread male DIN 11851	
-S4	Triclamp PN10 ; PN16		
-T4	Thread female NPT : removable		
-S5	Flanges Rosista PN10		
-NN	Without process connection		
Material of wetted parts	SS	Stainless steel	
	PF	Teflon lining	
	NN	Without wetted parts	Only with RAMCNN
Cone / Float	-nnnn	See tables 13 ... 15	
	-NNNN.....	Without measuring tube / without float	Only with RAMCNN
Indicator / Transmitter	-T	Indicator local	
	-E	Indicator electronic	
	-G	Indicator electronic with Profibus PA	Only with output 429
	-H	Indicator electronic HART	Only with output 424
	-N	Without indicator	Only with housing NN
Housing type	66	Housing rectangular yellow : Polyamid	
	90	Housing round blank : SS	
	91	Housing round yellow : Al	
	NN	Without housing	Only with indicator N
Power supply / Output	240	230 V AC : 4-wire : 0-20 mA	Only with indicator E. Not with limit switches
	244	230 V AC : 4-wire : 4-20 mA	Only with indicator E. Not with limit switches
	140	115V AC : 4-wire : 0-20 mA	Only with indicator E. Not with limit switches
	144	115V AC : 4-wire : 4-20 mA	Only with indicator E. Not with limit switches
	430	24V DC : 3-wire : 0-20 mA	Only with indicator E
	434	24V DC : 3-wire : 4-20 mA	Only with indicator E
	424	24V DC : 2-wire : 4-20 mA	Only with indicator E or H
	429	Profibus PA / Foundation Fieldbus 9 ... 32VDC	Only with indicator G. Not with limit switches
NNN	Without power supply	Only with indicator T or N	
Options		/[]	See separate table on next page	

T5.EPS

Specify the following when ordering :

- 1) Model, suffix code and option code
- 2) Fluid name ; Process temperature ; Process density ; Process pressure ; Process viscosity
- 3) For gases : Condition of the scale (st. or actual)
- 4) Options : Tag No. ; Customer specific notes

OPTIONS

Options	Option code	Description	Restrictions
Indicator	/A5 /A8 /A12 /A13 /A14 /A16 /A17 /A18	Thread for cable gland ASME 1/2" NPT female With scale for indicator US-engineering units Thread for cable gland ISO M20 x 1.5 female Housing colour green Indicator on 95mm extension Housing colour green Housing colour yellow	Not with option /A13 Only without indicator; Not with options /KS1, /KS2, /KF1, /KN1, /SS1, /NS1, /FS1 Only for indicator E + H Not with option /KF1; not with option /A5 Only for housing 66 + 91 Only for housing 90 + 91 Only for housing 90 Only for housing 90
Marking	/B0 /B1 /B4 /B8 /BG /BD	Tag plate (SS) on flange and marking on scale Tag plate (SS) fixed by wire and marking on scale Neutral version Customer provides marking on label Customer specific notes on scale Dual Scale	Plate 12 x 40 mm; max. 45 digits and 8 digits for HART-Tag (only indicator H) Plate 12 x 40 mm; max. 45 digits and 8 digits for HART-Tag (only indicator H) Not with option /P6 and Ex-proof type Max. 45 digits Adjustment only possible for 1 fluid
Limit switches	/K1 /K2 /K3 /K6 /K7 /K8 /K9 /K10	MIN-contact MAX-contact MIN-MAX-contact; MIN-MIN-contact; MAX-MAX-contact MIN-contact "Fail Safe"- version MAX-contact "Fail Safe"- version MIN-MAX-contact "Fail Safe"- version MIN-MIN contact "Fail Safe"- version MAX-MAX-contact "Fail Safe"- version	Not for power supply 14n + 24n Not for power supply 14n + 24n Not for power supply 14n + 24n Not for power supply 14n + 24n Not for power supply 14n + 24n Not for power supply 14n + 24n Not for power supply 14n + 24n Not for power supply 14n + 24n
Pulse output	/CP	Pulse output, isolated	Only for power supply 14n + 24n
Facing (process connection)	/D10 /D11	EN raised face B2 : Ra 0.8 - 3.2 EN groove	Only for EN-flanges (D2;D4) Only for EN-flanges (D2;D4)
Ex-proof type	/KS1 /KS2 /KN1 /FS1 /SS1 /NS1 /KF1	ATEX intrinsically safe "ia" ATEX intrinsically safe "ia" + dust proof ATEX category 3G "nL" / 3D FM intrinsically safe approval for electronic transmitter, CSA intrinsically safe approval for limit switches (USA and Canada) SAA approval (Australia) NEPSI approval (China) for RAMC ATEX flame proof "d" / dust proof	Only for power supply 434+430+424+429; for indicator T only with limit switches Only for power supply 434+430+424; for indicator T only with limit switches; only for housing 91 Only for power supply 434+430+424; for indicator T only with limit switches Only for power supply 424; for indicator T only with limit switches Only for power supply 424; for indicator T only with limit switches /K6 to /K10; only for housing 90 Only for power supply 424, 430, 434; only for housing 90; for indicator T only with limit switches Only for housing 91; only for power supply 434+430+424
Test and certificates	/H1 /H3 /P2 /P3 /P6 /PM3 /PP /PT	Oil + fat free for wetted surfaces acc. ASTM G93-03, level C Certificate pure water application Certificate of Compliance with the order acc. to EN 10204: 2004- 2.1 As /P2 + Test report acc. to EN 10204: 2004- 2.2 Material certificate acc. to EN 10204: 2004- 3.1 PAMI test (3 test points: process connection inlet, metering tube, process connection outlet) Pressure test report measuring system Flowtable for conversion	Only for metallic pressurized parts; not for process connection R4 + T4 Only for SS material of wetted parts
GOST approvals	/QR1 /QR2	Russian GOST approval Kasachian GOST approval	
Damping	/SD	Float damping system	Only for stainless steel; not for cone 81 + 82; only for gas application
Heat tracing	/T1 /T2 /T3 /T4 /T5 /T6	Heat tracing, process connection R 1/4" Heat tracing, process connection DN15 PN40 Heat tracing, process connection DN25 PN40 Heat tracing, process connection ASME 1/2" 150# Heat tracing, process connection ASME 1" 150# Heat tracing, process connection 1/4" NPT	Only for SS material of wetted parts Only for SS material of wetted parts Only for SS material of wetted parts Only for SS material of wetted parts Only for SS material of wetted parts Only for SS material of wetted parts
Power supply for electronic transmitter	/U2F /U3F /U2K /U3K	SINEAX B811, 85 - 250 V AC, EEx i SINEAX B811, 24 V AC/DC, EEx i SINEAX B811, 85 - 250 V AC, EEx i, HART compatible SINEAX B811, 24 V AC/DC, EEx i, HART compatible	Only for indicator E + H Only for indicator E + H Only for indicator E + H Only for indicator E + H
Power supply for limit switch(es) (transmitter relay)	/W1A /W1B /W2A /W2B /W2E /W4A /W4B /W4E	KFA5-SR2-Ex1.W / 115 V AC, 1 channel KFA5-SR2-Ex2.W / 115 V AC, 2 channels KFA6-SR2-Ex1.W / 230 V AC, 1 channel KFA6-SR2-Ex2.W / 230 V AC, 2 channels KHA6-SH-Ex1 / 230 V AC, 1 channel, Fail Safe KFD2-SR2-Ex1.W / 24 V DC, 1 channel KFD2-SR2-Ex2.W / 24 V DC, 2 channels KHD2-SH-Ex1 / 24 V DC, 1 channel, Fail Safe	Only for limit switches /K1 + /K2 + /K3 Only for limit switches /K1 + /K2 + /K3 Only for limit switches /K1 + /K2 + /K3 Only for limit switches /K1 + /K2 + /K3 Only for limit switches /K6 to /K10 Only for limit switches /K1 + /K2 + /K3 Only for limit switches /K1 + /K2 + /K3 Only for limit switches /K1 + /K2 + /K3 Only for limit switches /K6 to /K10
Flange protection	/QK	Flange covers (flange EN)	Only for flange EN
Instruction manuals	/IE n /ID n /IF n	Quantity of instruction manuals in English Quantity of instruction manuals in German Quantity of instruction manuals in French	n = 1 to 9 selectable *) n = 1 to 9 selectable *) n = 1 to 9 selectable *) *) if no instruction manual is selected, only a CD with instruction manuals is shipped with the flowmeter

T6.EPS

FLOW TABLES FOR METAL TUBES

Table 14

Pos.	Measuring ranges for water and liquids						Measuring ranges for air and gases						
	recommended combination			Alternative combination			recommended combination			Alternative combination			
	Max. Flow m ³ /h ^{c)}	Cone / Float combination	pressure loss ^{a)} mbar	viscosity ^{b)} mPa*s	Cone / Float combination	pressure loss ^{a)} mbar	Max. Flow m ³ /h i. N. e) scfm ^{f)}	Cone / Float combination	pressure loss ^{a)} mbar	Cone / Float combination	pressure loss ^{a)} mbar		
1	0.025	43 S0	40	10	-	-	0.7	43 S0	45	-	-		
	0.04	44 S0	40	80	-	-	1.1	44 S0	45	-	-		
	0.063	47 S0	40	80	-	-	1.7	47 S0	45	-	-		
	0.1	51 S0	40	80	-	-	2.8	51 S0	45	-	-		
	0.13	53 L1	12	50	-	-	3.6	53 L1	13	-	-		
	0.16	-	-	-	53 M1	15	5.0	-	-	53 M1	21		
	0.22	0.5	12	50	-	-	-	-	-	-	-		
	0.25	1.12	40	100	54 M1	15	6.0	54 L1	13	-	-		
	0.32	1.4	-	-	57 L1	12	8.5	-	-	54 M1	21		
	0.4	1.8	40	50	57 M1	15	9.0	57 L1	13	-	-		
2	0.5	2.2	-	-	61 L1	12	13	8.0	-	57 M1	21		
	0.63	2.8	40	50	61 M1	15	15	9.0	61 L1	13	-		
	0.8	3.5	-	-	62 L1	12	20	12	-	61 M1	21		
	1.0	4.5	40	100	62 M1	15	23	14	62 L1	13	-		
	1.6	7.0	40	100	-	-	32	20	-	62 M1	21		
	2.3	10.4	-	-	62 V1	45	45	28	-	62 S1	45		
	1.3	5.7	17	50	-	-	36	23	63 L2	19	-		
	2.1	9.2	-	-	64 L2	17	47	29	-	63 M2	23		
	2.5	11.2	42	30	64 M2	17	55	35	64 L2	19	-		
	4	18	42	10	-	-	80	50	-	-	-		
3	6	27	-	-	64 V2	43	110	70	-	64 S2	47		
	3.2	14	13	20	-	-	90	57	67 L5	16	-		
	5.0	22	-	-	71 L5	13	120	75	-	-	25		
	6.3	28	47	30	-	-	150	90	71 L5	16	-		
	8.5	37	-	-	72 L5	13	180	115	-	-	25		
	10	45	47	5	72 M5	19	230	140	72 L5	16	-		
	16	70	47	5	-	-	320	200	-	-	25		
	25	110	-	-	72 V5	63	470	290	-	-	54		
	25	110	60	10	-	-	500	320	73 L8	30	-		
	40	180	60	10	-	-	800	500	74 L8	30	-		
4	63	280	60	10	-	-	1300	800	77 L8	30	-		
	100	450	70	10	-	-	-	-	-	-	-		
	130	570	70	10	-	-	-	-	-	-	-		
	5	6	100	450	70	10	-	-	-	-	-	-	
			130	570	70	10	-	-	-	-	-	-	
			6	100	450	70	10	-	-	-	-	-	-
				130	570	70	10	-	-	-	-	-	-

a) Pressure loss at the float with water or air.
 b) For higher viscosity the specified precision is no more guaranteed.
 c) Flow is referred to 20°C and 1 bar abs
 d) Flow referred to 0°C and 1.013 bar abs at operation conditions of 20°C and 1.013 bar abs
 e) Flow in US Gallons per minute referred to 60°F and 14.7 PSI at operation conditions of 70°F and 14.7 PSI abs
 f) Flow in Standard cubicfeet per minute referred to 60°F and 14.7 PSI at operation conditions of 70°F and 14.7 PSI abs

For your special application please use the Rota Yokogawa Sizing-Program

PROCESS CONNECTION- AND FLOW-TABLE FOR TUBES WITH PTFE LINING

Table 15

Pos.	Process connection				Measuring range for Water / Liquids			Measuring range for Air / Gases				
	EN-Flange		ASME-Flange		Max. Flow m ³ /h ^{c)} gpm ^{d)}	Cone / Float combination Code	Pressure Loss ^{a)} mbar	Visco- sity ^{b)} mPa*s	Max. Flow		Cone / Float combination Code	Pressure loss ^{a)} mbar
	PN 16 Code	PN 40 Code	150 lbs Code	300 lbs Code					m ³ /h ^{c)}	m ³ /h i. N. ^{e)} scfm ^{f)}		
2	D2	D4	A1	A2	0,1 0,16 0,25 0,4 0,63 1,0	51 A1 52 A1 53 A1 54 A1 57 A1 61 V1	16 16 16 16 16 18	50 50 50 50 50 50	3,5 5,0 8,5 13 20 34	3,3 4,7 8,0 12 18 32	51 A1 52 A1 53 A1 54 A1 57 A1 61 V1	20 20 20 20 20 22
3	-	DN15 DN25	3/4" 1"	250 250	1/4" 1/2"	250 250	20 20	30 30	50 85	47 80	62 A2 63 A2	25 25
4	-	DN50 DN65 DN80	2 1/2" 3"	250 260	2 1/2" 3"	270 270	22 20	20 30	- 130 200 350	- 120 180 330	63 V2 64 A5 67 A5 71 A5	- 25 25 25
5	DN100	DN80	3 1/2" 4"	250 270	3 1/2" 4"	270 270	25 25	10 30	- 500 850	- 470 800	71 V5 72 V8 73 V8	- 27 27
6	DN100	DN100	4"	250 270	4"	270 270	30 10	10	- - -	- - -	- - -	- - -

bold = recommended

(1) L = Mounting length

a) Pressure loss at the float with water or air

b) As from this viscosity the specified precision is no more guaranteed.

c) Flow is referred to 20°C and 1 bar abs

d) Flow in US Gallon per minute at 70°F

e) Flow referred to 0°C and 1,013 bar abs at operation conditions of 20°C and 1,013 bar abs

f) Flow in Standard cubicfeet per minute referred to 60°F and 14,7PSI at operation conditions of 70°F and 14,7PSI abs

For your special application please use the Rota Yokogawa Sizing-Program

TEMPERATURE GRAPHS FOR RAMC METAL DESIGN, STANDARD AND Ex-i

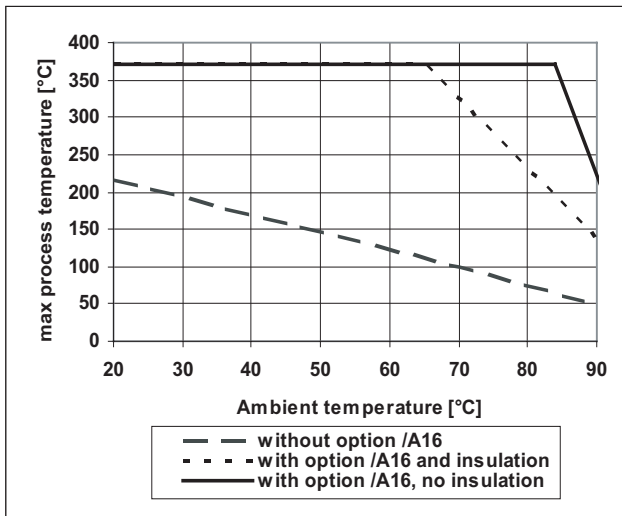

fig. 7a RAMC : - type 90 / 91
- only with indicator

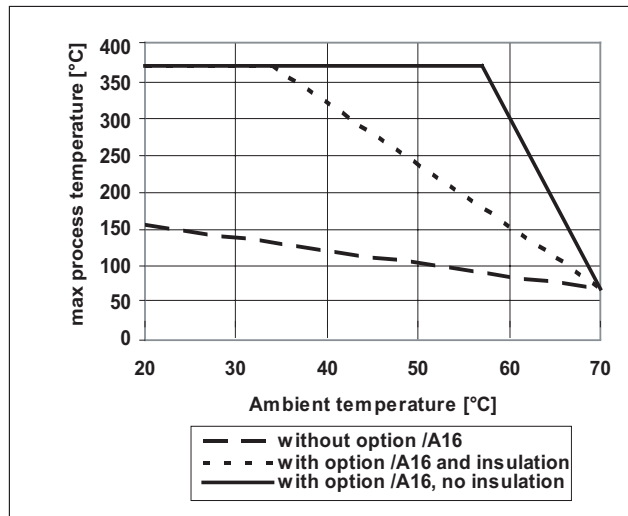

fig. 7b RAMC : - type 90 / 91
- with limit switches
- with electronic transmitter

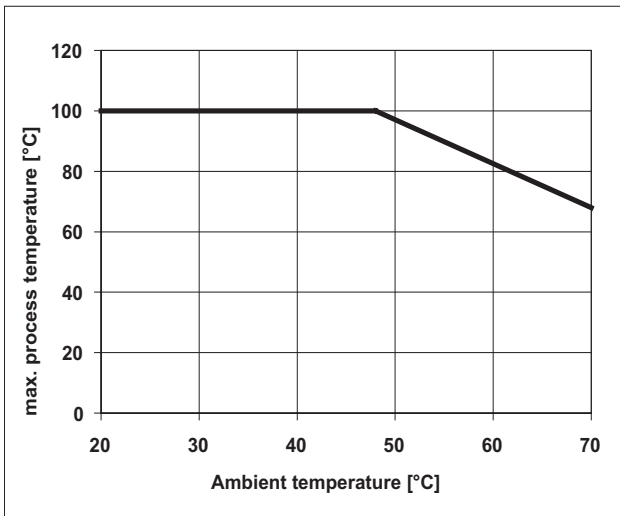

fig. 7c RAMC : - type 66
- with or without limit switches
- with or without electronic transmitter

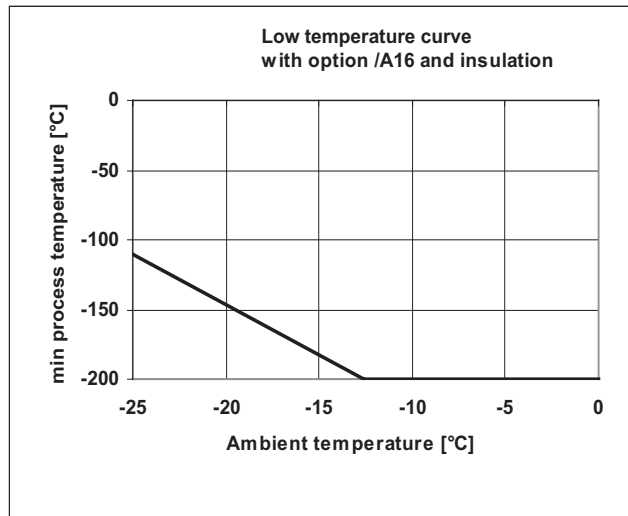

fig. 7d RAMC : - type 90 / 91
- with or without limit switches
- with or without electronic transmitter

T10.EPS

The temperature graphs are reference values for size DN100. They may be influenced negative by trapped heat, external heat sources or radiated heat and influenced positive for smaller sizes.

Insulation means rock wool between tube and indicator.

Units with electronic transmitter can show the temperature of the internal transmitter on the display or HART-type can show and supervise the internal temperature by HART-communication.

Units with PTFE lining are usable up to 130°C.

For units with explosion proof certification the temperature limits according the certificate of conformity must be regarded (see also page 4 and 5).

The minimum ambient temperature for indicators is -25°C except units with option /KF1 and /KS2 (lower temperatures on request).

DIMENSIONS AND WEIGHTS

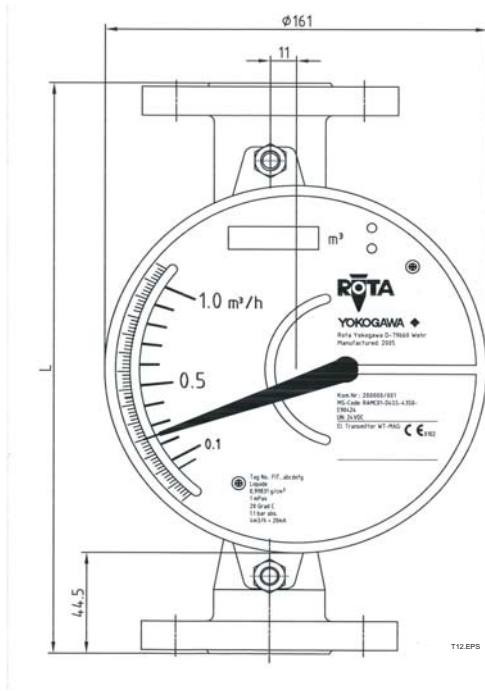

fig. 8a Front view housing type 90

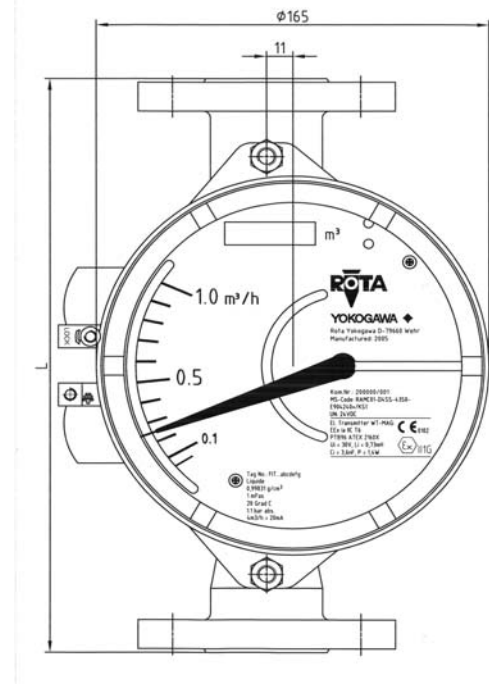

fig. 8b Front view housing type 91

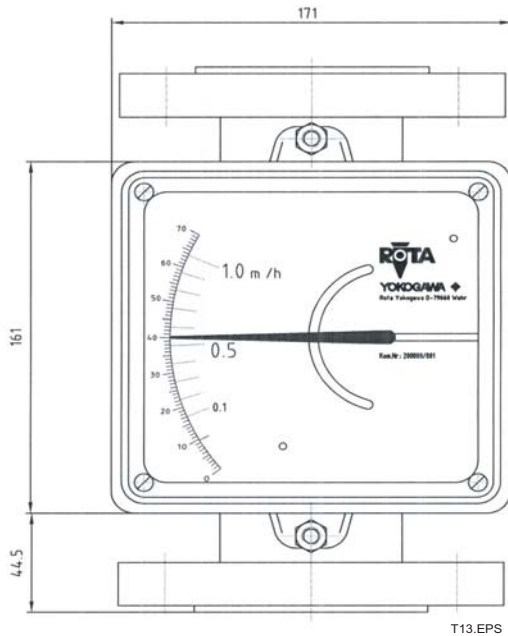

fig. 8c. Front view housing type 66

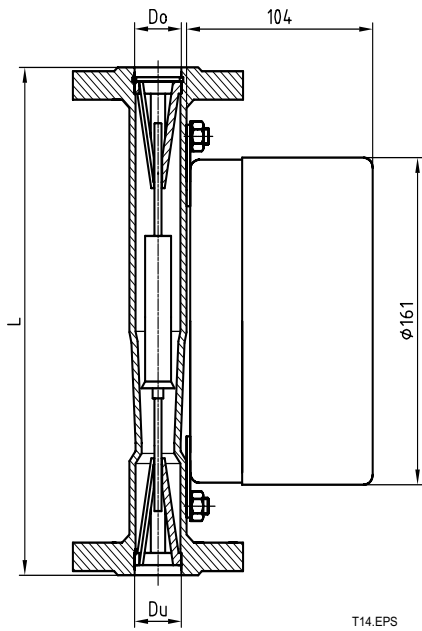

fig. 9 Metal version

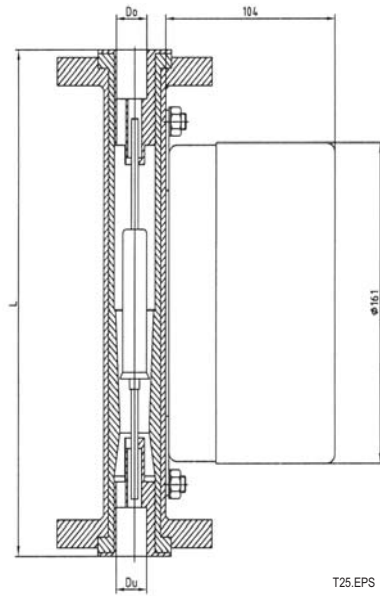

fig. 10 Metal version with lining

Table 16

Inner diameter of stainless steel flanges								Inner diameter of flanges with PTFE-lining			
Pos.*)	EN- flange without groove		ASME- flange			Rosista- flange	Pos.*)	EN- flange	ASME- flange	Du = Do	
	Size	Du mm	Do mm	Size	Du mm	Do mm		Du = Do mm	Size		Size
1	DN15 - DN50	20.7	20.7	1/2" - 1"	20.7	20.7	20.7				
2	DN15 - DN50	29.5	29.5	1/2"	20.7	20.7	29.5	2	DN15 - DN25	3/4" - 1"	23.5
				3/4" - 2"	29.5	29.5					
3	DN25 - DN50	45.2	45.2	1"	32.2	32.2	45.2	3	DN25 - DN50	1 1/4" - 1 1/2"	36.0
				1 1/4" - 2"	45.2	45.2					
4	DN50 - DN100	62.0	76.0	2"	62.0	65.5	-	4	DN50 - DN80	2 1/2" - 3"	66.0
				2 1/2" - 3"	62.0	76.0					
5	DN80 - DN150	94.0	94.0	3" - 6"	94.0	94.0	-	5	DN80 - DN100	3 1/2" - 4"	82.0
6	DN100 - DN150	116.0	116.0	4" - 6"	116.0	116.0	-	6	DN100	4"	110.0

*) see table 12; 13; 14

T23.EPS

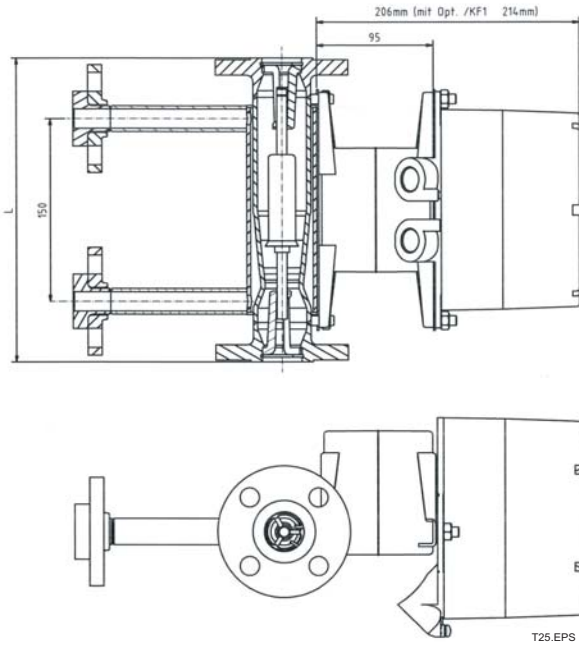

fig. 11 RAMC type 91 and Option /A16 and T2

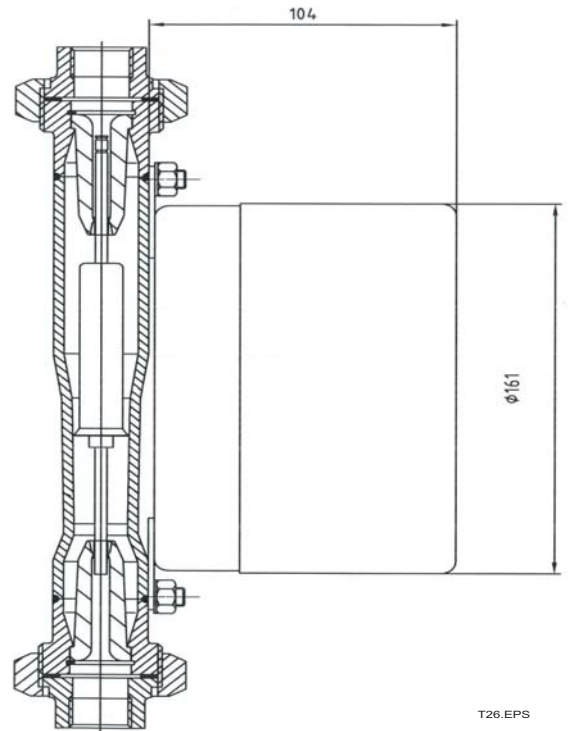

fig. 12 RAMC with connection R4/ T4

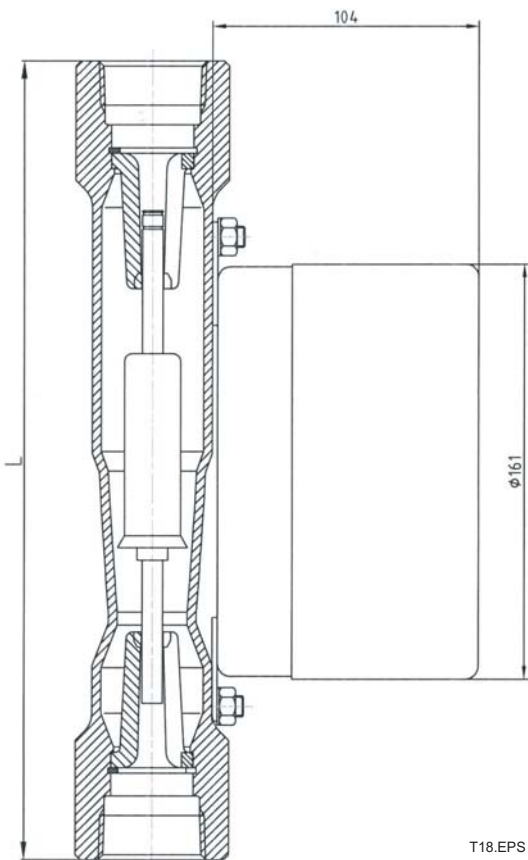

fig. 13 RAMC with connection T6/ G6

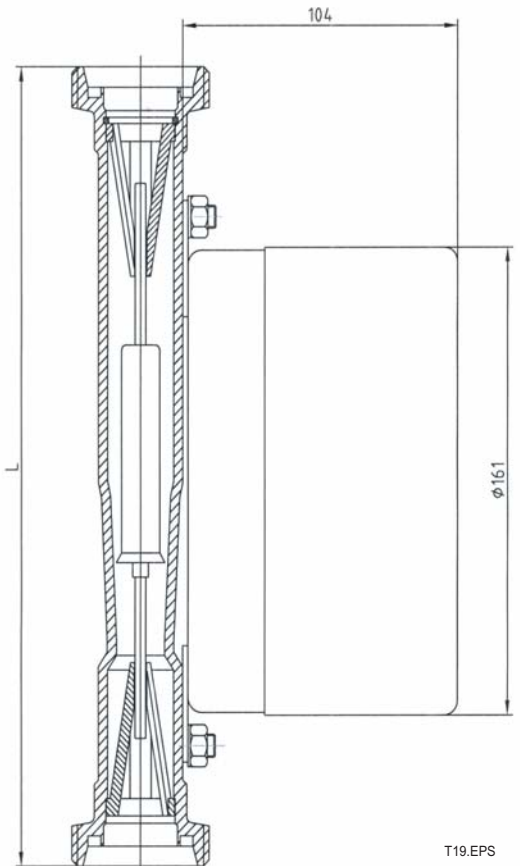

fig. 14 RAMC with connection S2

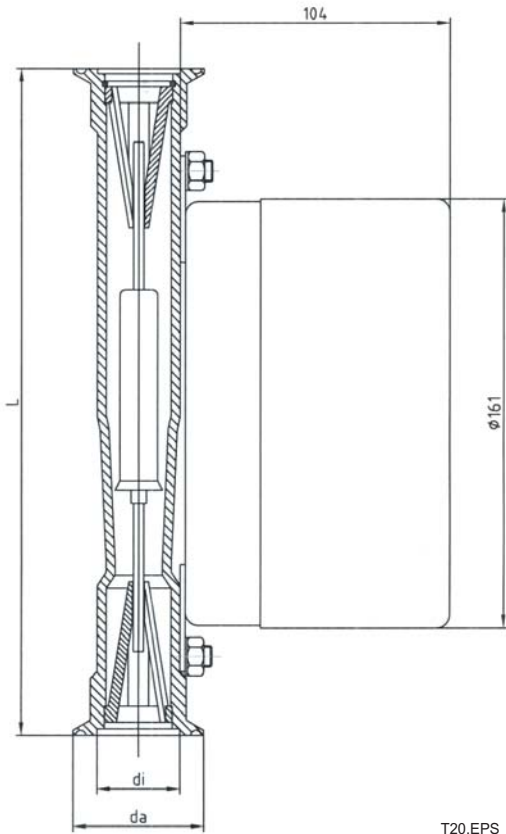

fig. 15 RAMC with connection S4

Table 17 Diameter for connection sizes S4

Position *)	Size [mm]	di [mm]	da [mm]
1	DN25 / 1"	36	50.5
	DN32	36	50.5
	DN40 / 1-1/2"	36	50.5
2	DN25 / 1"	36	50.5
	DN32	36	50.5
	DN40 / 1-1/2"	36	50.5
3	DN50 / 2"	47,8	64
4	DN65	72.1	91
	3"	72.1	91
5	DN100 / 4"	97.6	119

*) see table 12;13,14

T21.EPS

Table 18 Weights

Position *)	Weight / kg
1	3 - 5
2	3 - 5
3	6.5 - 8
4	8.6 - 11
5	13 - 16
6	17 - 20

*) see table 12;13,14

Indicator on extension (option /A16)
additional 1 kg

T22EPS

YOKOGAWA HEADQUARTERS
9-32, Nakacho 2-chome,
Musashinoshi
Tokyo 180
Japan
Tel. (81)-422-52-5535
Fax (81)-422-55-1202
E-mail: webinfo@mis.yokogawa.co.jp
www.yokogawa.com

YOKOGAWA CORPORATION OF AMERICA
2 Dart Road
Newnan GA 30265
United States
Tel. (1)-770-253-7000
Fax (1)-770-251-2088
E-mail: info@yca.com
www.yca.com

YOKOGAWA EUROPE B.V.
Databankweg 20
3821 AL AMERSFOORT
The Netherlands
Tel. +31-33-4641 611
Fax +31-33-4641 610
E-mail: info@nl.yokogawa.com
www.yokogawa.com/eu

YOKOGAWA ELECTRIC ASIA Pte. Ltd.
5 Bedok South Road
Singapore 469270
Singapore
Tel. (65)-241-9933
Fax (65)-241-2606
E-mail: webinfo@yas.com.sg
www.yokogawa.com.sg

Yokogawa has an extensive sales and distribution network. Please refer to the European web-site (www.yokogawa-europe.com) to contact your nearest representative.

Manufactured by:
ROTA YOKOGAWA
Rheinstr. 8
D-79664 Wehr
Germany



YOKOGAWA ◆