

Operating Instructions
Model 9100D DIN rail Mount
Sensor-Mate[®] HART
Temperature Transmitter

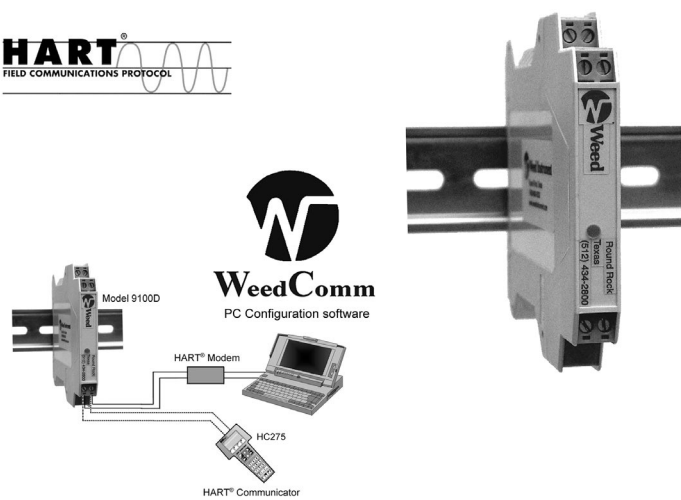

Safety Message

Instructions and procedures in the operating instructions may require special precautions to ensure the safety of the personnel performing the operations. Information that potentially raises safety issues is indicated by safety pictograms and symbols. Please refer to the safety messages before performing an operation preceded by pictograms and symbols, see chapter 1.4.

Though the information provided herein is believed to be accurate, be advised that the information contained herein is NOT a guarantee of satisfactory results. Specifically, this information is neither a warranty nor guarantee, expressed or implied, regarding performance; merchantability, fitness, or other matter with respect to the products; and recommendation for the use of the product / process information in conflict with any patent. Please note that the manufacturer reserves the right to change and / or improve the product design and specifications without notice.



Warning!

Failure to follow these installation guidelines could result in death or serious injury.

- Make sure only qualified personnel perform the installation.

Explosions could result in death or serious injury.

- Do not remove the connection head cover in explosive atmospheres when the circuit is live.
- Before connecting a Model 275 HART[®] Communicator in an explosive atmosphere, make sure the instruments in the loop are installed in accordance with intrinsically safe or non-incendive field wiring practices.
- Verify that the operating atmosphere of the transmitter is consistent with the appropriate hazardous locations certifications.
- All connection head covers must be fully engaged to meet explosion-proof requirements.
- Do not remove the thermowell while in operation.

Electrical shock could cause death or serious injury.

- Use extreme caution when making contact with the leads and terminals.

Short form instructions

Using the following short form instructions you can commission your system easily and quickly:

Safety notes	page 5
Installation	page 7
Wiring	page 9
<p style="text-align: center;">Commissioning (including a description of the unit functions) A complete description of all the functions as well as a detailed overview of the function matrix can be found in this chapter.</p> <p style="text-align: center;">Quick Setup - Fast entry into the unit configuration for standard measuring.</p>	page 12
<p style="text-align: center;">Trouble-shooting / fault-finding If problems occur after commissioning or during operation always start fault finding using the check list. Special questions will act as a guide to the cause of the fault and the necessary cure.</p>	page 20

Table of contents

1	Safety notes	5	6	Commissioning	12
1.1	Designated use	5	6.1	Installation and function check	12
1.2	Installation, commissioning and operation	5	6.2	Commissioning	12
1.3	Operational safety	6	7	Maintenance	20
1.4	Safety pictograms and symbols	6	8	Accessories	20
2	Identification	7	9	Trouble-shooting	20
2.1	Unit identification	7	9.1	Trouble-shooting instructions	20
2.2	Registered trademarks	7	9.2	Application fault messages	20
3	Installation	7	9.3	Application faults without messages	21
3.1	Installation conditions	7	10	Technical Data	22
3.2	Installation	8	10.1	Function and system design	22
4	Wiring	9	10.2	Input	22
4.1	Overview	9	10.3	Output	23
4.2	Measurement unit connection	9	10.4	Power supply	24
4.3	Ground the Transmitter	10	10.5	Performance characteristics	24
5	Operation	11	10.6	Installation conditions	25
5.1	Communication	11	10.7	Environmental conditions	26
			10.8	Mechanical construction	26
			10.9	Certificates and approvals	27

1 Safety notes

Safe and secure operation of the DIN rail transmitter can only be guaranteed if the operating instructions and all safety notes are read, understood and followed.

1.1 Designated use

Designated use

- The unit is a presettable temperature transmitter for resistance thermometer (RTD), thermocouple (TC) as well as resistance and voltage sensors. The unit is constructed for mounting on a DIN rail.
- The manufacturer cannot be held responsible for damage caused by misuse of the unit.
- Separate Ex documentation is part of this operating manual, for measurement systems in hazardous areas. The installation conditions and connection values indicated in these instructions must be followed!

1.2 Installation, commissioning and operation

Installation, commissioning and operation

The unit is constructed using the most up-to-date production equipment and complies to the safety requirements of the local guidelines. The temperature transmitter is fully factory tested according to the specifications indicated on the order. However, if it is installed incorrectly or is misused, certain application dangers can occur. Installation and wiring of the unit must only be done by trained, skilled personnel who are authorized to do so by the plant operator. This skilled staff must have read and understood these instructions and must follow them to the letter. The plant operator must make sure that the measurement system has been correctly wired to the connection schematics. Due to its construction, the transmitter cannot be repaired. When disposing of the DIN rail transmitter, please take note of the local disposal regulations.

Electrical temperature sensors such as RTD's and thermocouples produce low-level signals proportional to their sensed temperature. The temperature transmitter converts the low-level sensor signal to a standard 4 to 20 mA DC signal that is relatively insensitive to lead length and electrical noise. This current signal is then transmitted to the control room via two wires.

The transmitter can be commissioned before or after installation. It may be useful to commission it on the bench, before installation, to ensure proper operation and to become familiar with its functionality. Make sure the instruments in the loop are installed in accordance with intrinsically safe or non-incendive field wiring practices before connecting a HART[®] communicator in an explosive atmosphere.

The printed circuit board of the transmitter is protected by the DIN rail housing, resisting moisture and corrosive damage. Verify that the operating atmosphere of the transmitter is consistent with the appropriate hazardous locations certifications.



Warning!

Electrical shock could cause death or serious injury. If the sensor is installed in a high voltage environment and a fault or installation error occurs, high voltage may be present on the transmitter leads and terminals.

1.3 Operational safety

Operational safety

Hazardous areas

When installing the unit in a hazardous area, the national safety requirements must be met. Make sure that all personnel are trained in these areas. Strict compliance with installation instructions and ratings as stated in this documentation is mandatory.

The measuring device complies with the general safety requirements in accordance with IEC61010, the EMC requirements of IEC61326 and NAMUR recommendation NE21 and NE43.

Technical advancement

The manufacturer reserves the right to modify technical data without prior notice. Your distributor can supply you with current information and updates to these Operating Instructions.

1.4 Safety pictograms and symbols

Safety pictograms and symbols

Safe and reliable operation of this unit can only be guaranteed if the safety notes and warnings in these operating instructions are followed. The safety notes in these instructions are highlighted using the following symbols.



Note!

This icon indicates activities and actions that, if not followed correctly, could have an indirect influence on the unit operation or could lead to an unforeseen unit reaction.



Caution!

This icon indicates activities and actions that, if not followed correctly, could lead to faulty unit operation or even damage to the unit.



Warning!

This icon indicates activities and actions that, if not followed correctly, could lead to personal injury, a safety risk or even total damage to the unit.



Explosion protected, type examined operating equipment

If one of these icons is on the device's nameplate, the device can be used in hazardous areas.



Hazardous area

This symbol identifies the hazardous area in the diagrams in these Operating Instructions.

- Devices that are used in hazardous areas or cables for such devices must have the corresponding type of protection.



Safe area (non-hazardous areas)

This symbol identifies the non-hazardous area in the diagrams in these Operating Instructions.

- Devices in non-hazardous areas must also be certified if connection cables run through a hazardous area.

2 Identification

2.1 Unit identification

Unit identification

For model name, type and brand please see legend plate on the temperature transmitter.

CE Mark, declaration of conformity

The devices are designed to meet state-of-the-art safety requirements, have been tested, and left the factory in a condition in which they are safe to operate. The devices comply with the applicable standards and regulations in accordance with IEC61010 "Protection Measures for Electrical Equipment for Measurement, Control, Regulation and Laboratory Procedures" and with the EMC requirements of IEC61326.

The measuring system described in these Operating Instructions thus complies with the statutory requirements of the EC Directives. The manufacturer confirms successful testing of the device by affixing to it the CE mark.

2.2 Registered trademarks

- HART[®]
Registered trademark of HART[®] Communication Foundation, Austin, Tx, USA
- PROFIBUS[®]
Registered trademark of PROFIBUS Nutzerorganisation e. V., Karlsruhe, Germany
- Microsoft[®] Windows NT[®] and Windows[®] 2000
Registered trademarks of Microsoft Corporation, Redmond, USA

3 Installation

3.1 Installation conditions

Installation conditions

Caution!

The unit must only be powered by a power supply that operates using an IEC 61010-1 compliant energy limited circuit: 'SELV or Class 2 circuit'.

- When installing and operating the unit, please take note of the allowable ambient temperature (see chapter 10 "Technical Data").
- When using the unit in a hazardous area, the limits indicated in the certification must be adhered to (see control drawing).

Dimensions

The DIN rail transmitter dimensions can be found in chapter 10 "Technical Data".

Installation point

Installation on DIN rail according to EN 50 022-35, e.g. in control panel.

Installation angle

There are no limits as to the angle of installation.

3.2 Installation

3.2.1 Typical installation

Installation

For installation, proceed as follows:

- Attach the DIN rail temperature transmitter to a suitable rail or panel.
- Attach thermowell (1) to pipe or process container wall. Install and tighten the thermowell before applying process pressure.
- Attach necessary extension nipples and adapters (3) to the thermowell (1). Seal the nipple and adapter threads with teflon tape.
- Screw the sensor (2) into the thermowell (1). Install drain seals if required for harsh environments or to satisfy code requirements.
- Screw the connection head (4) to the sensor assembly.
- Attach the sensor lead wires to the connection head terminals.
- Connect sensor wires from the terminals inside the head to the DIN rail temperature transmitter (5).
- Install and tighten the connection head cover. Enclosure covers must be completely engaged to meet explosion-proof area requirements.

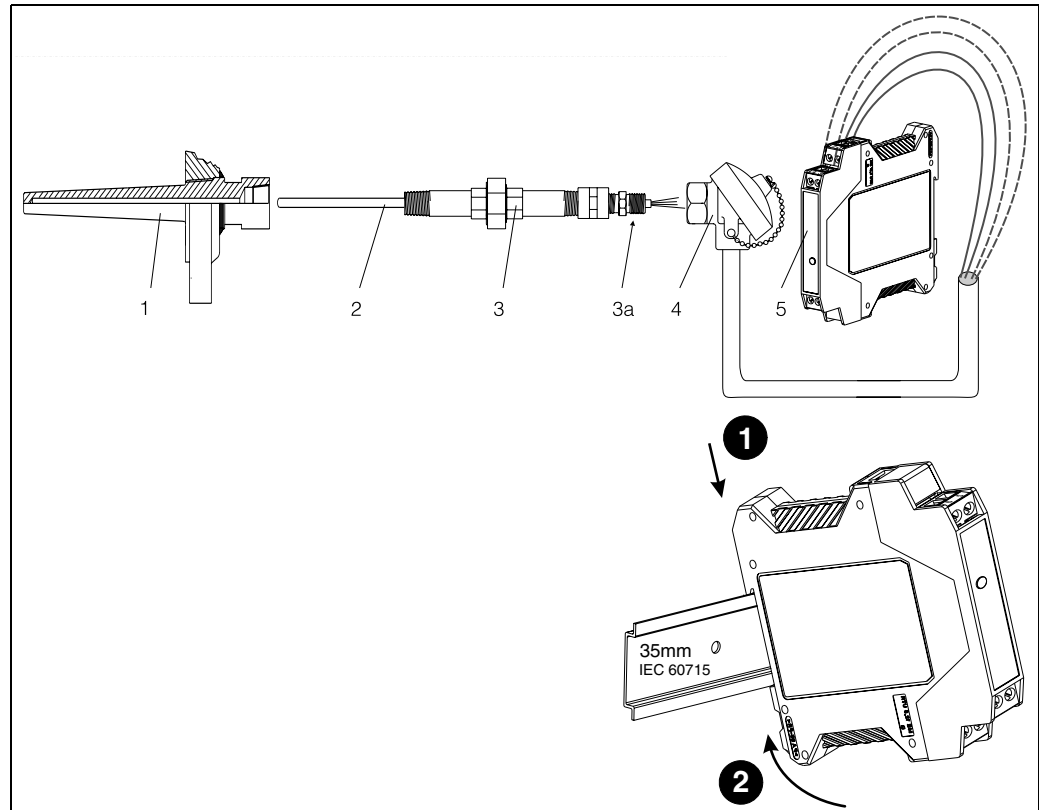

fig. 1: Installation of DIN rail temperature transmitter.

- 1 thermowell
- 2 sensor
- 3 extension nipples and adapters
- 3a spring loaded fitting
- 4 connection head
- 5 DIN rail temperature transmitter

4 Wiring

4.1 Overview

Wiring overview

Terminal layout

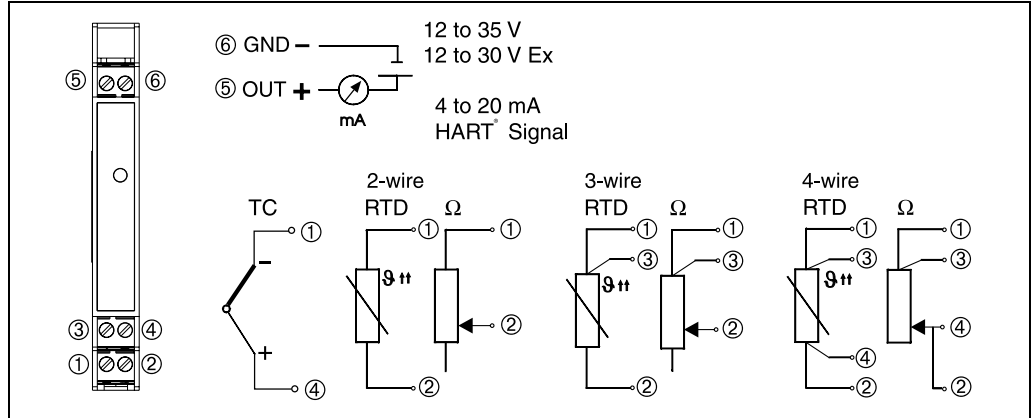

fig. 2: DIN rail transmitter wiring

4.2 Measurement unit connection

Measurement unit connection



Caution!

Switch off power supply before opening housing cover of the temperature sensor. Do not install or connect the unit to power supply before the sensor is connected to the transmitter. If this is not followed, parts of the electronic circuit will be damaged.

4.2.1 Sensors

Connect the sensor cables to the respective DIN rail transmitter terminals (Terminals 1 to 4) by following the wiring diagram (see fig. 2). Wiring plugs are removable for easy access.

4.2.2 Output signal and power supply

Connect the cable wires from the power supply to terminal 5 and 6 according to the wiring diagram (see fig. 2). For convenient installation, the connection is designed as a removable plug, so the connection can be made on the terminals, then plug in the connection socket to the transmitter housing.



Note!

The screws on the terminals must be screwed in tightly.

4.2.3 HART® connection

Connection is made directly using the 4 to 20 mA signal cables or the communication sockets fitted to a power supply or barrier. In order to connect the transmitter in a hazardous area, please read the separate Ex documentation.



Note!

The measurement circuit must have a load of at least 250 Ω (see fig. 3 and see fig. 4).

Connection of a 'HART[®] communicator Model 275':

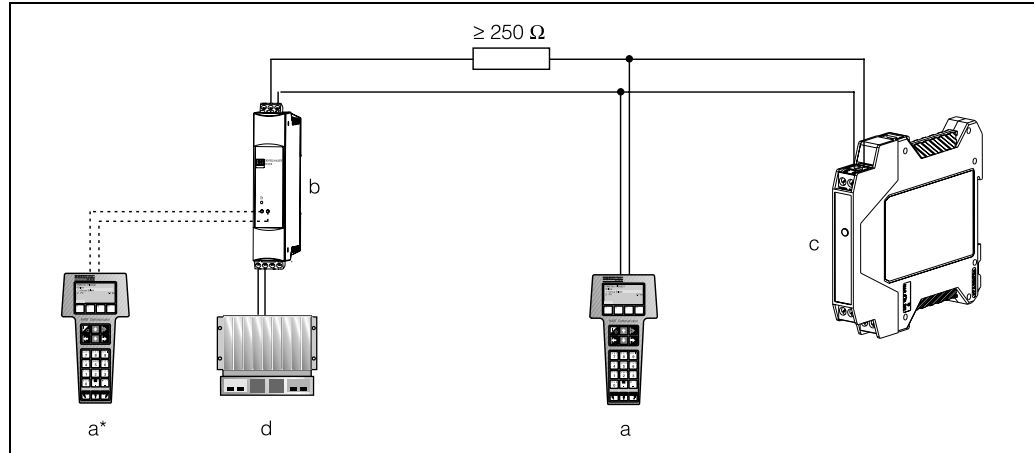

fig. 3: Electrical connection of the HART[®] communicator Model 275
a = HART[®] module, a = HART[®] module connected to the communication sockets of a power supply, b = Loop power supply, c = DIN rail temperature transmitter, d = PLC with passive input*

Connection of the HART[®] -modem



Note!
 Set the modem DIP switch to 'HART[®]'!

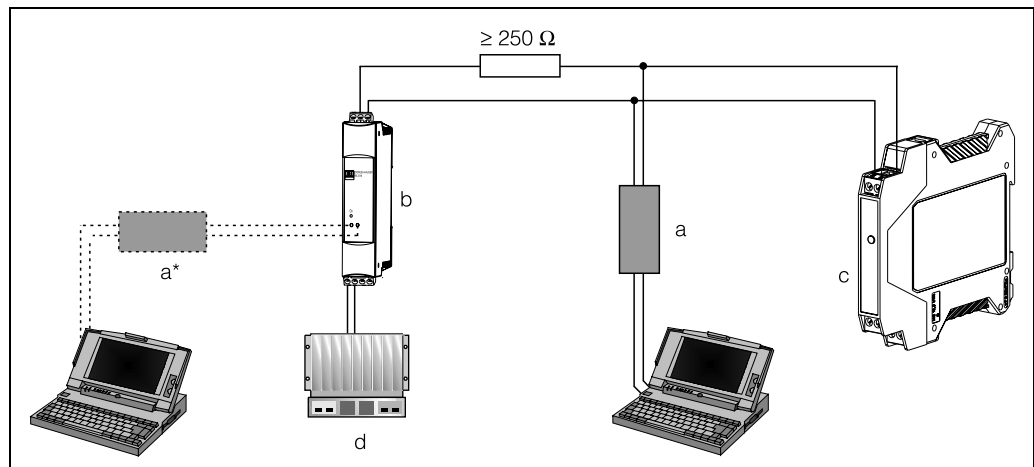

fig. 4: Electrical connection of the HART[®] -modem
a = HART[®] -modem (in combination with a PC operating software), a = HART[®] -modem connected to the communication sockets of a power supply unit, b = Loop power supply, c = DIN rail temperature transmitter, d = PLC with a passive input*

4.3 Ground the Transmitter

The transmitter will operate with the current signal loop either floating or grounded. However, the extra noise in floating systems affects many types of readout devices. If the signal appears noisy or erratic, grounding the current signal loop at a single point may solve the problem. The best place to ground the loop is at the negative terminal of the power supply. Do not ground the current signal loop at more than one point. The transmitter is galvanically isolated to 2 kV AC (from the sensor input to the output), so the input circuit may also be grounded at any single point. When using a grounded thermocouple, the grounded junction serves as this point.

5 Operation

5.1 Communication

The DIN rail temperature transmitter is set up using the HART[®] protocol. The values measured can also be read using the HART[®] protocol. In order to do this the user has two possibilities:

- Operation using a universal hand operated module “HART[®] Communicator Model 275”.
- Operation using a PC and operating software as well as a HART[®] modem.

5.1.1 HART[®] Communicator Model 275

Selection of the unit functions using the “HART[®] Communicator” is done using various menu levels as well as with the help of a special HART[®] function matrix (see page 14).



Note!

- When using the HART[®] communicator all parameters can be read out, however, programming is locked. It is possible to access the HART[®] function matrix by entering 281 in the LOCK function. This condition remains even after a power failure. The HART[®] function matrix can be locked again by entering the personal code number.
- More detailed information on the ‘HART[®] Communicator Model 275’ can be found in the respective operating manual in the carrying case.

6 Commissioning

6.1 Installation and function check

Installation check

Monitor all connections making sure they are tight. In order to guarantee fault-free operation, the terminal screws must be screwed tightly onto the connection cables.

Function check

Measuring the analog 4 to 20 mA output signal or following failure signals:

Measurement range under-cut	linear fall to 3.8 mA
Measurement range excess	linear rise to 20.5 mA
Sensor break; sensor short circuit ^a	≤ 3.6 mA or ≥ 21 mA

a. not for thermocouples

6.2 Commissioning

Commissioning

Once the power supply has been connected, the DIN rail temperature transmitter is operational.



Note!

If there are any communication faults in the Microsoft[®] Windows NT[®] Version 4.0, Windows[®] 2000, or Windows[®] XP operating system, please follow these instructions:

Switch of the 'FIFO active' setting.

In order to do this proceed as follows:

- Windows NT[®] Version 4.0:
Using the menu 'START' → 'SETTINGS' → 'SYSTEM CONTROL' → 'CONNECTIONS' select the menu point 'COM-Port'. Switch off the 'FIFO active' command off using the menu path 'SETTINGS' → 'EXPANDED'.
- Windows[®] 2000:
Select 'Advanced settings for COM1' from the 'START' → 'SETTINGS' → 'SYSTEM CONTROL' → 'SYSTEM' → 'HARDWARE' → 'DEVICE MANAGER' → 'CONNECTIONS (COM and LPT)' → 'COMMUNICATION CONNECTION (COM1)' → 'CONNECTION SETTINGS' → 'ADVANCED' menu. Deactivate "Use FIFO buffer".
- Windows[®] XP:
Select "Port settings" from connections Port (Com 1) → 'START' → 'SETTING' → 'SYSTEM' → 'HARDWARE' → 'DEVICE MANAGER' → 'PORTS (COM and LPT)' → 'COMMUNICATION PORT (COM1)' → 'PORT SETTING' → 'ADVANCED' menu. Deactivate "Use FIFO buffer".

6.2.1 Quick Setup

Using the Quick Setup, the operator is led through all the most important unit functions that must be set up for standard measurement operation of the unit.

Using the 'HART[®] Communicator Model 275' a quick setup of the black highlighted fields of the HART[®] function matrix (see fig. 6) is possible.

6.2.2 Configuration with HART® protocol and "HART® Communicator Model 275"



Note!

Selection of all DIN rail transmitter functions using the 'HART® Communicator Model 275' is done with various menu levels with the help of the function matrix (see fig. 6). All transmitter functions are described in 6.2.4 "Description of unit functions".

What needs to be done:

1. Switch on 'HART® Communicator Model 275':
 - Measurement unit is not yet connected. The HART® main menu appears. This menu level appears for all HART® programming independent of the type of instrumentation. Information on off-line programming can be found in the 'HART® Communicator Model 275' operating manual.
 - Measuring unit is connected. The menu level "Online" appears. In this "Online" menu level the actual measured data such as measured value (PV) and output current (AO) are continuously displayed. Entry into the transmitter operating matrix is done using the line "Matrix Parameter". This matrix systematically contains all HART® accessible functions.
2. Using "Matrix Parameter" the function group can be selected (e.g. basic calibration) and then followed by the required function, e.g. "Sensor input".
3. Enter numeric values or change settings. Then acknowledge using the F4 "Entry" function key.
4. "SEND" appears when operating the F2 function key. Once the F2 key has been pressed all values entered in the hand module are transmitted to the transmitter measurement system.
5. A return to the "Online" menu level is made using the F3 "HOME" function key. Here, the actual transmitter values measured with the new settings can be read.



Note!

- When using the 'HART® Communicator Model 275' all parameters can be read out, however, programming is blocked. It is possible to access the HART® function matrix by entering 281 in the LOCK function. This condition remains even after a power failure. The HART® function matrix can be locked again by entering the personal code number.
- More detailed information on the 'HART® Communicator Model 275' can be found in the respective operating manual in the carrying case.

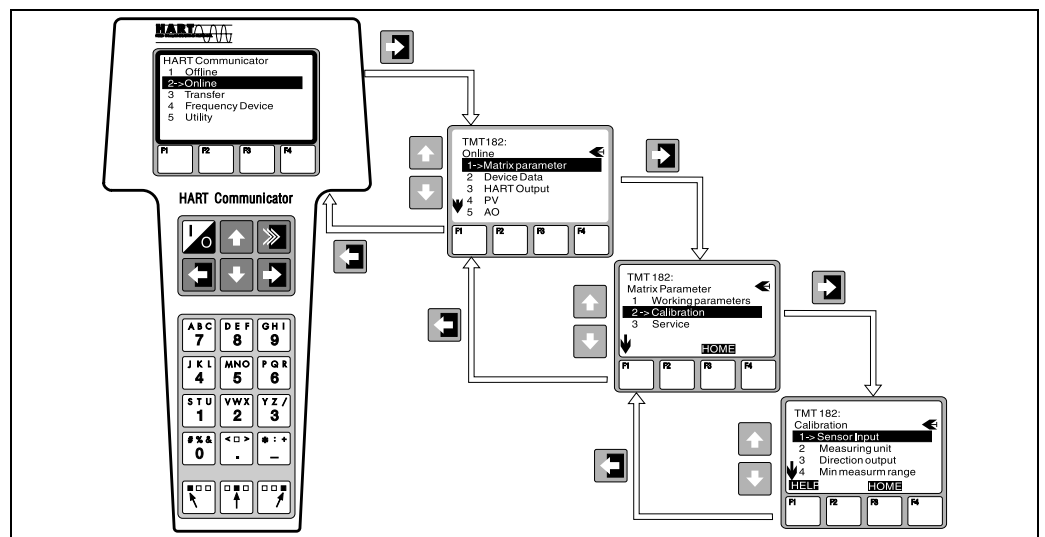

fig. 5: Configuration of the 'HART® Communicator Model 275' example, "Sensor input"

HART® function matrix

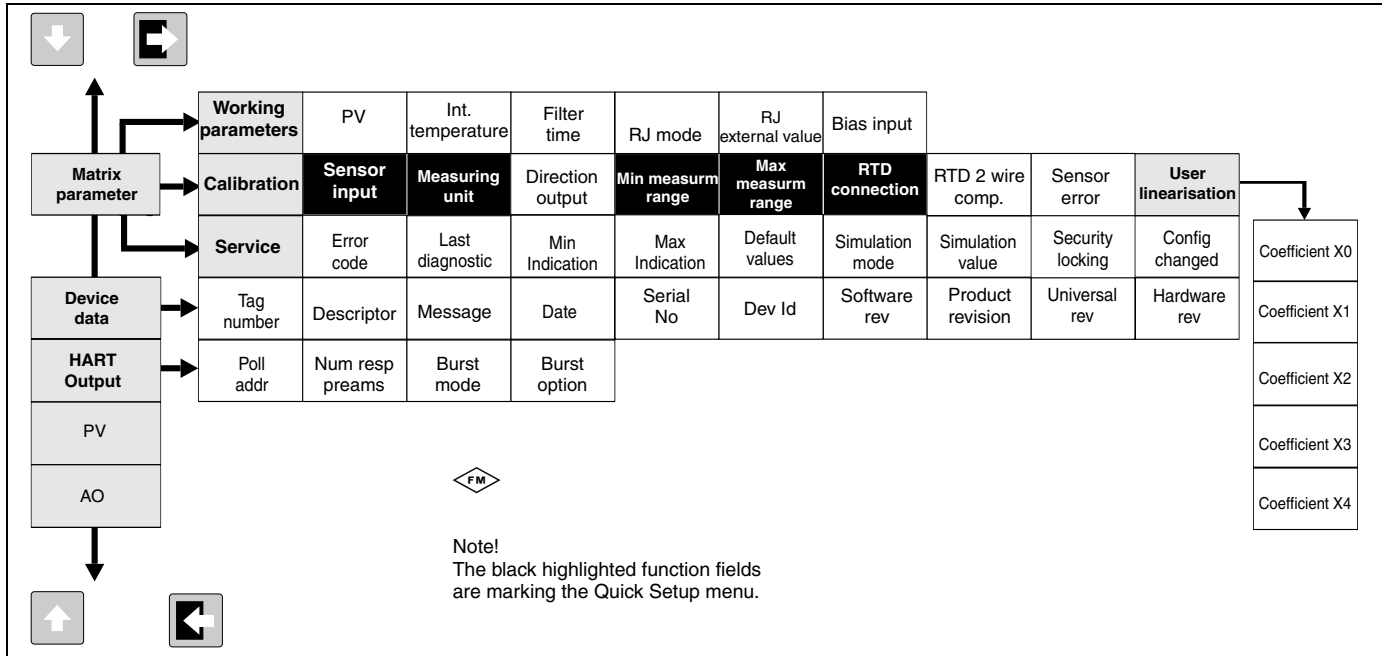

fig. 6: HART® function matrix

6.2.3 Configuration using HART® protocol and PC configuration software

The configuration of the transmitter can be done using both the HART® protocol and the PC configuration software. The following table shows the structure of the interactive menu led operation of the PC configuration software.

Configurable parameters (Unit function description see "Description of unit functions" on page 15)	
Standard settings	<ul style="list-style-type: none"> - Sensortype - Connection mode (2-,3-, or 4-wire connection on RTD) - Units (°C, °F or K) - Measurement range start value - Measurement range end value - Coefficient X0 to X4 (on sensor type polynom RTD/TC) - Temp.-compensation (on sensor type polynom TC)
Expanded settings	<ul style="list-style-type: none"> - Cold junction compensation internal/external (on TC) - external temperature (on TC with cold junction compensation external) - Cable resistance compensation (on RTD 2-wire connection) - Fault condition reaction - Output (4 to 20 mA/20 to 4 mA) - Damping (filter) - Offset - TAG (Measurement point description) - Descriptor
Service functions	<ul style="list-style-type: none"> - Output simulation (on/off) - Reset to default - Series number (only display) - Operation code (=release code 281)

For detailed operating instructions for the PC configuration software, please read the documentation (**Readme.txt**) contained in the PC software (see folder "**Doc**").

Customer-specific linearization

Customer-specific linearization and sensor matching are activated after the **POLYNOM RTD** sensor type is selected. Pressing the “**LINEARIZATION**” key starts the **SMC 32** module. The sensor's support points and temperature deviation are entered in the **SMC 32**. Pressing the “**CALCULATE**” key calculates the linearization and “**OK**” adopts it into the PC configuration software. Linearization coefficients X0 to X4 are entered into the operating matrix or in the 'HART® Communicator Model 275'.

6.2.4 Description of unit functions











The following table contains a listing and description of all unit functions of the HART® protocol that can be used for setting up the DIN rail temperature transmitter.















Note!

Factory default values are shown in bold text.





The 'HART® Communicator Model 275' display is indicated by the following symbol .

 PV (Primary value)	Display of actual measured temperature. Display: 7-digit number with floating decimal point and engineering unit. (e.g. 199.98 Ohm; -62.36 °C, 407.76 °F)
 Int. temperature	Display of the actual measured temperature of the internal comparison measurement point.  Note! Display: 7-digit number with floating decimal point and engineering unit.
Damping  Filter time	Digital filter selection 1 st grade. Input: 0 to 100 seconds 0 sec.
Cold junction  RJ Mode	Selection of internal (Pt100) or external (32 to 176 °F/0 to 80 °C) cold junction compensation. Entry: internal; external internal  Note! Entry only possible on selection of thermocouple (TC) in unit function SENSOR TYPE. ¹
External temp.  RJ external value	Entry of external cold junction value. Entry: -40.00 to 185.00 °F (-40.00 to 85.00 °C) (°C, °F, K) 0 °C  Note! Entry only possible on selection of an external cold junction compensation in unit function RJ MODE.
Offset  Bias input	Entry of zero point correction (Offset). Entry: -18.00 to 18.00 °F (10.00 to 10.00 °C) (°C, °F, K) 0.00 °C  Note! Entry returns to factory default values when changing sensor type!

Sensortype  Sensor input	Entry of sensor used: <table border="1"> <thead> <tr> <th>Sensor type</th> <th>Range start</th> <th>Range end value</th> </tr> </thead> <tbody> <tr> <td>-10..75 mV</td> <td>-10 mV</td> <td>75 mV</td> </tr> <tr> <td>10..400 Ohm</td> <td>10 Ω</td> <td>400 Ω</td> </tr> <tr> <td>10..2000 Ohm</td> <td>10 Ω</td> <td>2000 Ω</td> </tr> <tr> <td>Pt100 DIN</td> <td>-200 °C (-328 °F)</td> <td>850 °C (1562 °F)</td> </tr> <tr> <td>Pt100 JIS</td> <td>-200 °C (-328 °F)</td> <td>649 °C (482 °F)</td> </tr> <tr> <td>Pt500</td> <td>-200 °C (-328 °F)</td> <td>250 °C (482 °F)</td> </tr> <tr> <td>Pt1000</td> <td>-200 °C (-328 °F)</td> <td>250 °C (482 °F)</td> </tr> <tr> <td>Ni100</td> <td>-60 °C (-76 °F)</td> <td>180 °C (356 °F)</td> </tr> <tr> <td>Ni500</td> <td>-60 °C (-76 °F)</td> <td>150 °C (302 °F)</td> </tr> <tr> <td>Ni1000</td> <td>-60 °C (-76 °F)</td> <td>150 °C (302 °F)</td> </tr> <tr> <td>Polynom RTD</td> <td>-270 °C (-454 °F)</td> <td>2500 °C (4532 °F)</td> </tr> <tr> <td>Type B</td> <td>0 °C (32 °F)</td> <td>1820 °C (3308 °F)</td> </tr> <tr> <td>Type C</td> <td>0 °C (32 °F)</td> <td>2320 °C (4208 °F)</td> </tr> <tr> <td>Type D</td> <td>0 °C (32 °F)</td> <td>2495 °C (4523 °F)</td> </tr> <tr> <td>Type E</td> <td>-270 °C (-454 °F)</td> <td>1000 °C (1832 °F)</td> </tr> <tr> <td>Type J</td> <td>-210 °C (-346 °F)</td> <td>1200 °C (2192 °F)</td> </tr> <tr> <td>Type K</td> <td>-270 °C (-454 °F)</td> <td>1372 °C (2501 °F)</td> </tr> <tr> <td>Type L</td> <td>-200 °C (-328 °F)</td> <td>900 °C (1652 °F)</td> </tr> <tr> <td>Type N</td> <td>-270 °C (-454 °F)</td> <td>1300 °C (2372 °F)</td> </tr> <tr> <td>Type R</td> <td>-50 °C (-58 °F)</td> <td>1768 °C (3214 °F)</td> </tr> <tr> <td>Type S</td> <td>-50 °C (-58 °F)</td> <td>1768 °C (3214 °F)</td> </tr> <tr> <td>Type T</td> <td>-270 °C (-454 °F)</td> <td>400 °C (752 °F)</td> </tr> <tr> <td>Type U</td> <td>-200 °C (-328 °F)</td> <td>600 °C (1112 °F)</td> </tr> <tr> <td>Polynom TC</td> <td>-270 °C (-454 °F)</td> <td>2500 °C (4532 °F)</td> </tr> </tbody> </table> Pt100 DIN	Sensor type	Range start	Range end value	-10..75 mV	-10 mV	75 mV	10..400 Ohm	10 Ω	400 Ω	10..2000 Ohm	10 Ω	2000 Ω	Pt100 DIN	-200 °C (-328 °F)	850 °C (1562 °F)	Pt100 JIS	-200 °C (-328 °F)	649 °C (482 °F)	Pt500	-200 °C (-328 °F)	250 °C (482 °F)	Pt1000	-200 °C (-328 °F)	250 °C (482 °F)	Ni100	-60 °C (-76 °F)	180 °C (356 °F)	Ni500	-60 °C (-76 °F)	150 °C (302 °F)	Ni1000	-60 °C (-76 °F)	150 °C (302 °F)	Polynom RTD	-270 °C (-454 °F)	2500 °C (4532 °F)	Type B	0 °C (32 °F)	1820 °C (3308 °F)	Type C	0 °C (32 °F)	2320 °C (4208 °F)	Type D	0 °C (32 °F)	2495 °C (4523 °F)	Type E	-270 °C (-454 °F)	1000 °C (1832 °F)	Type J	-210 °C (-346 °F)	1200 °C (2192 °F)	Type K	-270 °C (-454 °F)	1372 °C (2501 °F)	Type L	-200 °C (-328 °F)	900 °C (1652 °F)	Type N	-270 °C (-454 °F)	1300 °C (2372 °F)	Type R	-50 °C (-58 °F)	1768 °C (3214 °F)	Type S	-50 °C (-58 °F)	1768 °C (3214 °F)	Type T	-270 °C (-454 °F)	400 °C (752 °F)	Type U	-200 °C (-328 °F)	600 °C (1112 °F)	Polynom TC	-270 °C (-454 °F)	2500 °C (4532 °F)
Sensor type	Range start	Range end value																																																																										
-10..75 mV	-10 mV	75 mV																																																																										
10..400 Ohm	10 Ω	400 Ω																																																																										
10..2000 Ohm	10 Ω	2000 Ω																																																																										
Pt100 DIN	-200 °C (-328 °F)	850 °C (1562 °F)																																																																										
Pt100 JIS	-200 °C (-328 °F)	649 °C (482 °F)																																																																										
Pt500	-200 °C (-328 °F)	250 °C (482 °F)																																																																										
Pt1000	-200 °C (-328 °F)	250 °C (482 °F)																																																																										
Ni100	-60 °C (-76 °F)	180 °C (356 °F)																																																																										
Ni500	-60 °C (-76 °F)	150 °C (302 °F)																																																																										
Ni1000	-60 °C (-76 °F)	150 °C (302 °F)																																																																										
Polynom RTD	-270 °C (-454 °F)	2500 °C (4532 °F)																																																																										
Type B	0 °C (32 °F)	1820 °C (3308 °F)																																																																										
Type C	0 °C (32 °F)	2320 °C (4208 °F)																																																																										
Type D	0 °C (32 °F)	2495 °C (4523 °F)																																																																										
Type E	-270 °C (-454 °F)	1000 °C (1832 °F)																																																																										
Type J	-210 °C (-346 °F)	1200 °C (2192 °F)																																																																										
Type K	-270 °C (-454 °F)	1372 °C (2501 °F)																																																																										
Type L	-200 °C (-328 °F)	900 °C (1652 °F)																																																																										
Type N	-270 °C (-454 °F)	1300 °C (2372 °F)																																																																										
Type R	-50 °C (-58 °F)	1768 °C (3214 °F)																																																																										
Type S	-50 °C (-58 °F)	1768 °C (3214 °F)																																																																										
Type T	-270 °C (-454 °F)	400 °C (752 °F)																																																																										
Type U	-200 °C (-328 °F)	600 °C (1112 °F)																																																																										
Polynom TC	-270 °C (-454 °F)	2500 °C (4532 °F)																																																																										
Temp. Compensation	Selection of temperature compensation of the cold junction when using customer specific linearization of the TC polynom Input: None, Type B, Type C, Type D, Type E, Type J, Type K, Type L, Type N, Type R, Type S, Type T, Type U None																																																																											
Unit  Measuring unit	Enter engineering units. Entry: °C °F K °C																																																																											
Output current  Direction output	Enter standard (4 to 20 mA) or inverse (20 to 4 mA) current output signal. Entry: 4 to 20 mA 20 to 4 mA 4 to 20 mA																																																																											
Range start value  Min. measurm. range	Entry: For limits see unit function SENSOR TYPE. 0 °C																																																																											
Range end value  Max. measurm. range	Entry: For limits see unit function SENSOR TYPE. 100 °C																																																																											
Connection  RTD connection	Entry of RTD connection mode Entry: 2 wire 3 wire 4 wire 3 wire  Note! Function field is only active on selection of resistance thermometer (RTD) in the unit function SENSOR TYPE.																																																																											

Cable resistance  RTD 2 wire comp.	Entry of cable compensation on RTD 2 wire connection. Entry: 0.00 to 30.00 Ohm 0.00 Ohm  Note! Function field is only active on selection of 2 wire cable connection in unit function CONNECTION TYPE.
Fault condition  Sensor error	Entry of failure signal on sensor open or short circuit. ^a Entry: max (≥ 21 mA) min (≤ 3.6 mA) max
Coefficient X0 ■ V3H0	Input of first coefficient for customer-specific linearization (polynome 4 th grade with five coefficients), see chapter 6.2.3
Coefficient X1 ■ V3H1	Input COEFFICIENT X1, see chapter 6.2.3.
Coefficient X2 ■ V3H2	Input COEFFICIENT X2, see chapter 6.2.3.
Coefficient X3 ■ V3H3	Input COEFFICIENT X3, see chapter 6.2.3.
Coefficient X4 ■ V3H4	Input COEFFICIENT X4, see chapter 6.2.3.
Error code	Display of actual error code. Display: See “Application fault messages” on page 20. 0
Last diagnostic	Display of previous error code. Display: See “Application fault messages” on page 20. 0
Config. changed	Parameter changes are done. Display: Yes/No No
Min indication	Display the minimum process value. The process value is accepted at the beginning of the measurement.  Note! Min. process value will be changed to the actual process value on access. On reset to factory default, the default value is entered. +10000
Max indication	Display the maximum process value. The process value is accepted at the beginning of the measurement.  Note! Max. process value will be changed to the actual process value on access. On reset to factory default, the default value is entered. -10000
Default values	Entry: 182 (Reset to factory default settings) 0

a. Not for thermocouples (TC)

Output simulation  Simulation mode	Entry of simulation mode. Entry: Off On Off
Output current  Simulation value	Entry of simulation value (current). Entry: 3.58 to 21.7 mA
Keycode  Security locking	Release code for setting up. Entry: Lock = 0 Release = 281 281
Tag  Tag number	Entry and display of measurement point description (TAG). Entry: 8 characters -
Descriptor	Entry and display of plant description. Entry: 16 characters -
Dev ID	Display of device generation
Software rev	Display of software version, e.g.: 11 indicates version 1.1
Product rev	Display of unit version, e.g.: 1.0000 indicates version 1.00.00

6.2.5 Supported HART[®] commands

No.	Description	Access
Universal Commands		
00	Read unique identifier	r
01	Read primary variable	r
02	Read p.v. current and percent of range	r
03	Read dynamic variables and p.v. current	r
06	Write polling address	w
11	Read unique identifier associated with tag	r
12	Read message	r
13	Read tag, descriptor, date	r
14	Read primary variable sensor information	r
15	Read primary variable output information	r
16	Read final assembly number	r
17	Write message	w
18	Write tag, descriptor, date	w
19	Write final assembly number	w
Common practice		
34	Write primary variable damping value	w
35	Write primary variable range values	w
38	Reset configuration changed flag	w
40	Enter/Exit fixed primary variable current mode	w
42	Perform master reset	w
44	Write primary variable units	w
48	Read additional transmitter status	r
59	Write number of response preambles	w
108	Write burst mode command number	w
109	Burst mode control	w
Specific		
144	Read matrix parameter	r
145	Write matrix parameter	w

7 Maintenance

Maintenance

The DIN rail temperature transmitter has no moving parts and requires minimal scheduled maintenance.

Sensor Checkout

To determine whether the sensor is at fault, replace it with another sensor or connect a test sensor locally at the transmitter to test remote sensor wiring. Select any standard, off-the-shelf sensor for use with a DIN rail temperature transmitter, or consult the factory for a replacement special sensor or transmitter combination.

8 Accessories

Accessories

PC configuration software WeedComm. Please contact your supplier when ordering!

9 Trouble-shooting

9.1 Trouble-shooting instructions

If faults occur after commissioning or during measurement, always start any trouble-shooting sequence using the following check. The user is led towards the possible fault cause and its rectification via question and answer.

9.2 Application fault messages

Application fault messages

Application fault messages are shown in the display of the 'HART[®] Communicator Model 275' once the menu point "ERROR CODE" has been selected.

Fault code	Cause	Action/cure
0	No fault, Warning	None
10	Hardware fault (unit defective)	Replace DIN rail transmitter
11	Sensor short circuit	Check sensor
12	Sensor cable open circuit	Check sensor
13	Reference measurement point defective	None
14	Unit not calibrated	Return DIN rail transmitter to manufacturer
106	Up-/Download active	None (will be automatically acknowledged)
201	Warning: Measured value too small	Enter other values for measured value range start
202	Warning: Measured value too large	Enter other values for measured value range end

Fault code	Cause	Action/cure
203	Unit is reset (to factory default settings)	None

9.3 Application faults without messages

Application fault without messages

General application faults

Fault	Cause	Action/cure
No communication	No power supply on 2 wire circuit	Check current loop
	Power supply too low (<11.5 V)	Connect cables correctly to terminal plan (polarity)
	Defective interface cable	Check interface cable
	Defective interface	Check PC interface
	Defective DIN rail transmitter	Replace DIN rail transmitter

Application faults for RTD connection (Pt100/Pt500/Pt1000/Ni100)

Fault	Cause	Action/cure
Fault current (≤ 3.6 mA or ≥ 21 mA)	Defective sensor	Check sensor
	Incorrect RTD connection	Reconnect cables correctly (connection diagram)
	Incorrect 2 wire connection	Connect cables correctly to terminal plan (polarity)
	Transmitter programming faulty (wire number)	Change parameter 'CONNECTION' (See "Description of unit functions" on page 15.)
	Programming	Thermocouple set up (see chapter 6.2.4); change to RTD
	Defective DIN rail transmitter	Replace DIN rail transmitter
Measured value incorrect/inaccurate	Faulty sensor installation	Install sensor correctly
	Heat conducted via sensor	Take note of sensor installation length
	Transmitter programming faulty (wire number)	Change parameter 'Connection type'
	Transmitter programming faulty (scale)	Change scale
	Wrong RTD used	Change parameter 'Sensor type'
	Sensor connection (2 wire)	Check sensor connections
	Sensor cable (2 wire) not compensated	Compensate cable resistance
	Offset incorrectly set	Check offset

Application faults for TC connection

Fault	Cause	Action/cure
Fault current (≤ 3.6 mA or ≥ 21 mA)	Sensor incorrectly connected	Connect sensor correctly to terminal plan (polarity)
	Defective sensor	Replace sensor
	Programming	Sensor type 'RTD' setup; set up correct thermocouple
	Incorrect 2 wire connection (current loop)	Connect the cables correctly (see connection diagram)
	Defective DIN rail transmitter	Replace DIN rail transmitter
Measured value incorrect/inaccurate	Faulty sensor installation	Install sensor correctly
	Heat conducted via sensor	Take note of sensor installation length
	Transmitter programming faulty (scale)	Change scale
	Incorrect thermocouple setup	Change parameter 'Sensor type'
	Incorrect cold junction setup	See chapter 'Operation' and 'Technical data'
	Offset incorrectly set up	Check offset
	Fault on the thermowell welded thermo wire (coupling of interference voltages)	Use sensor where the thermo wire is not welded

10 Technical Data

10.1 Function and system design

Measuring principle Electronic monitoring and conversion of input signals in industrial temperature measurement.

Measuring system The DIN rail temperature transmitter is a two wire transmitter with an analog output. It has measurement input for resistance temperature detectors (RTD) in 2-, 3- or 4-wire connection, thermocouples and voltage transmitters. Setup of the temperature transmitter is done using the HART[®] - Protocol with 'HART[®] Communicator Model 275' or PC operating software.

10.2 Input

Measured variable Temperature, resistance and voltage

Measuring range The transmitter monitors different measuring ranges depending on the sensor connection and input signals.

Type of input

Input	Designation	Measuring range limits	Min. span
Resistance temperature detectors (RTD) to IEC 751 ($\alpha = 0.00385$) to DIN 43760 ($\alpha = 0.006180$)	Pt100	-328 to 1562 °F (-200 to 850 °C)	18 °F (10 °C)
	Pt500	-328 to 482 °F (-200 to 250 °C)	18 °F (10 °C)
	Pt1000	-328 to 482 °F (-200 to 250 °C)	18 °F (10 °C)
	Ni100	-76 to 482 °F (-60 to 250 °C)	18 °F (10 °C)
	Ni500	-76 to 302 °F (-60 to 150 °C)	18 °F (10 °C)
	Ni1000	-76 to 302 °F (-60 to 150 °C)	18 °F (10 °C)
<ul style="list-style-type: none"> ■ Connection type: 2-, 3- or 4-wire connection ■ Software compensation of cable resistance possible in the 2 wire system (0 to 30 Ω) ■ Sensor cable resistance max. 20 Ω per cable in the 3 and 4 wire system ■ Sensor current: ≤ 0.2 mA 			
Resistance transmitter	Resistance Ω	10 to 400 Ω 10 to 2000 Ω	10 Ω 100 Ω
Thermocouples (TC) to NIST Monograph 175, IEC 584 to ASTM E988 to DIN 43710	Type B (PtRh30-PtRh6) ^a	32 to 3308 °F (0 to +1820 °C)	900 °F (500 °C)
	Type E (NiCr-CuNi)	-454 to 1832 °F (-270 to +1000 °C)	90 °F (50 °C)
	Type J (Fe-CuNi)	-346 to 2192 °F (-210 to +1200 °C)	90 °F (50 °C)
	Type K (NiCr-Ni)	-454 to 2501 °F (-270 to +1372 °C)	90 °F (50 °C)
	Type N (NiCrSi-NiSi)	-454 to 2372 °F (-270 to +1300 °C)	90 °F (50 °C)
	Type R (PtRh13-Pt)	-58 to 3214 °F (-50 to +1768 °C)	900 °F (500 °C)
	Type S (PtRh10-Pt)	-58 to 3214 °F (-50 to +1768 °C)	900 °F (500 °C)
	Type T (Cu-CuNi)	-454 to 752 °F (-270 to +400 °C)	90 °F (50 °C)
	Type C (W5Re-W26Re)	32 to 4208 °F (0 to +2320 °C)	900 °F (500 °C)
	Type D (W3Re-W25Re)	32 to 4523 °F (0 to +2495 °C)	900 °F (500 °C)
	Type L (Fe-CuNi)	-328 to 1652 °F (-200 to +900 °C)	90 °F (50 °C)
	Type U (Cu-CuNi)	-328 to 1112 °F (-200 to +600 °C)	90 °F (50 °C)
<ul style="list-style-type: none"> ■ Internal cold junction (Pt100) ■ Accuracy of cold junction: ± 1.8 °F (1 °C) 			
Voltage transmitter (mV)	Millivolt transmitter (mV)	-10 to 75 mV	5 mV

a.High measuring error increase for temperature lower than 572 °F (300 °C)

10.3 Output

Output signal Analog 4 to 20 mA, 20 to 4 mA

Breakdown information

Breakdown information to NAMUR NE 43

Breakdown information is created when the measuring information is invalid or not present anymore and gives a complete listing of all errors occurring in the measuring system.

		Signal (mA)
Under ranging	Standard	3.8
Over ranging	Standard	20.5
Sensor break; sensor short circuit low	To NAMUR NE 43	≤ 3.6
Sensor break; sensor short circuit high	To NAMUR NE 43	≥ 21

Source impedance max. $(V_{\text{Power supply}} - 12 \text{ V}) / 0.022 \text{ A}$ (current output)
 e.g. $(24 \text{ V} - 12 \text{ V}) / 0.022 \text{ A} = 545.5 \Omega$

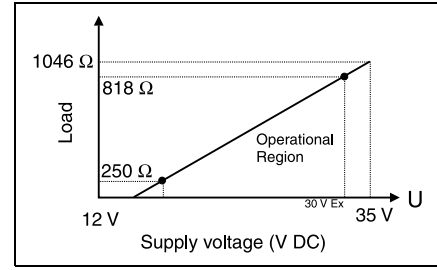

Transmission behavior Temperature linear, resistance linear, voltage linear

Filter 1st order digital filter: 0 to 100 s

Galvanic isolation $U = 2 \text{ kV AC}$ (input/output)

Input current required $\leq 3.5 \text{ mA}$

Current limit $\leq 23 \text{ mA}$

Switch on delay 4 s (during power up $I_a \leq 3.8 \text{ mA}$)

10.4 Power supply

Electrical connection See "Overview" on page 9.

Supply voltage $U_b = 12 \text{ to } 35 \text{ V}$, polarity protected (For hazardous location please see control drawing)

10.5 Performance characteristics

Response time 1 s

Reference operating conditions Calibration temperature: $73.4 \text{ }^\circ\text{F} \pm 9 \text{ }^\circ\text{F}$ ($+23 \text{ }^\circ\text{C} \pm 5 \text{ }^\circ\text{C}$)

Maximum measured error

	Type	Measurement accuracy ¹
Resistance temperature detectors RTD	Pt100, Ni100 Pt500, Ni500 Pt1000, Ni1000	0.36 °F (0.2 °C) or 0.08% 0.9 °F (0.5 °C) or 0.20% 0.54 °F (0.3 °C) or 0.12%
Thermocouple TC	K, J, T, E, L, U N, C, D S, B, R	typ. 0.9 °F (0.5 °C) or 0.08% typ. 1.8 °F (1.0 °C) or 0.08% typ. 3.6 °F (2.0 °C) or 0.08%

	Measurement range	Measurement accuracy ^a
Resistance transmitter (Ω)	10 to 400 Ω 10 to 2000 Ω	$\pm 0.1 \Omega$ or 0.08% $\pm 1.5 \Omega$ or 0.12%
Voltage transmitters (mV)	-10 to 75 mV	$\pm 20 \mu\text{V}$ or 0.08%

a.% is related to the adjusted measurement range. The value to be applied is the greater.

Influence of supply voltage $\leq \pm 0.01\%/V$ deviation from 24 V
 Percentages refer to the full scale value.

Influence of ambient temperature (Temperature drift)

- Resistance thermometer (RTD):
 $T_d = \pm(8.3 \text{ ppm}/^\circ\text{F} * \text{max. span} + 27.8 \text{ ppm}/^\circ\text{F} * \text{calibrated span}) * \Delta \vartheta$
 $T_d = \pm(15 \text{ ppm}/\text{K} * \text{max. span} + 50 \text{ ppm}/\text{K} * \text{calibrated span}) * \Delta \vartheta$
- Resistance thermometer Pt100:
 $T_d = \pm(8.3 \text{ ppm}/^\circ\text{F} * (\text{full scale point or } 20 \text{ mA temperature} + 328) + 27.8 \text{ ppm}/^\circ\text{F} * \text{span}) * \Delta \vartheta$
 $T_d = \pm(15 \text{ ppm}/\text{K} * (\text{full scale point or } 20 \text{ mA temperature} + 200) + 50 \text{ ppm}/\text{K} * \text{span}) * \Delta \vartheta$
- Thermocouple (TC):
 $T_d = \pm(27.8 \text{ ppm}/^\circ\text{F} * \text{max. span} + 27.8 \text{ ppm}/^\circ\text{F} * \text{calibrated span}) * \Delta \vartheta$
 $T_d = \pm(50 \text{ ppm}/\text{K} * \text{max. span} + 50 \text{ ppm}/\text{K} * \text{calibrated span}) * \Delta \vartheta$

$\Delta \vartheta$	Deviation of the ambient temperature according to the reference condition (73.4 °F ± 9 °F) (+23 °C ± 5 K).
Calibrated span	100 °F if unit calibrated from 50 °F to 150 °F.
max. span	Pt100 would be 1890 °F (1050 °C).
Full scale point or 20 mA temperature	150 °F if unit calibrated from 50 °F to 150 °F.

Influence of load $\pm 0.02\%/100 \Omega$
 Values refer to the full scale value

Long-term stability $\leq 0.18 \text{ }^\circ\text{F}/\text{year}$ (0.1 °C/year) or $\leq 0.05\%/year$
 Values under reference operating conditions. % refer to the set span. The highest value is valid.

Influence of cold junction Pt100 IEC 751 Cl. B (internal cold junction for thermocouples TC)

10.6 Installation conditions

Installation instructions

- Installation angle:
no limit
- Installation area:
Installation on DIN rail, e.g. in control panel

10.7 Environmental conditions

Ambient temperature limits	-40 to 185 °F (-40 to +85 °C) for Ex-area, see Ex-certification or control drawing
Storage temperature	-40 to 212 °F (-40 to +100 °C)
Climate class	as per IEC 60654-1, class C
Condensation	allowed
Degree of protection	NEMA 1 (IP 20)
Shock and vibration resistance	4g / 2 to 150 Hz as per IEC 60 068-2-6

Electromagnetic compatibility (EMC)

CE Electromagnetic Compatibility Compliance

The device meets all requirements listed under IEC 61326 Amendment 1, 1998 and NAMUR NE 21

This recommendation is a uniform and practical way of determining whether the devices used in laboratory and process control are immune to interference with an objective to increase its functional safety.

Discharge of static electricity	IEC 61000-4-2	6 kV cont., 8 kV air	
Electromagnetic fields	IEC 61000-4-3	80 to 1000 Hz	10 V/m
Burst (signal)	IEC 61000-4-4	1 kV 2 kV(B) ^a	
Transient voltage	IEC 61000-4-5	1 kV unsym. / 0.5 kV sym.	
HF coupling	IEC 61000-4-6	0.15 to 80 MHz	10 V
Line interference	IEC 61000-4-16	10 kHz to 150 kHz	10 V

a. self recovery

10.8 Mechanical construction

Design, dimensions

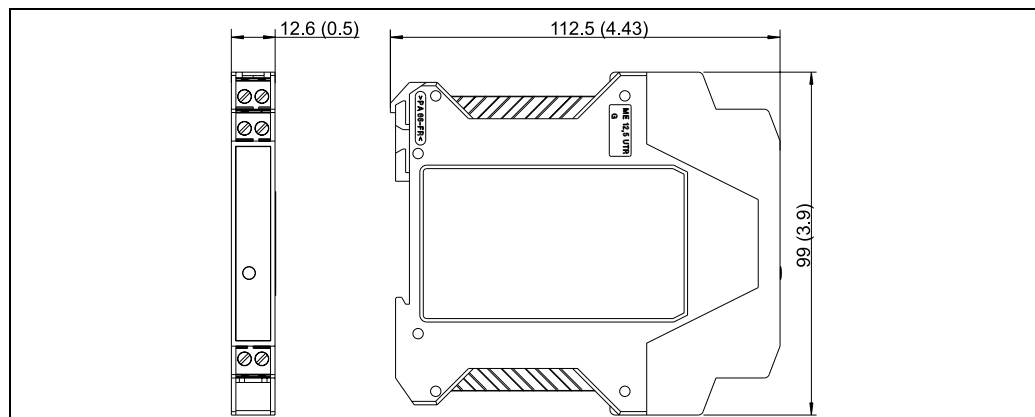

fig. 7: Dimensions of the DIN rail transmitter in mm (inches)

Weight	approx. 3.2 oz (90 g)
Material	■ Housing:

Plastic Polycarbonate (PC)/ABS, UL 94V0

Terminals Keyed plug-in screw terminals, core size max. 16 AWG solid, or strands with ferrules.

10.9 Certificates and approvals

CE-Mark The measurement system fulfills the requirements demanded by the EU regulations. The manufacturer acknowledges successful unit testing by adding the CE mark.

Hazardous area approvals FM IS, Class I, Div. 1+2, Group A, B, C, D
 CSA IS, Class I, Div. 1+2, Group A, B, C, D
 ATEX II2(1) G EEx ia IIC T4/T5/T6

Other standards and guidelines

- IEC 60529:
Degrees of protection by housing (IP-Code)
- IEC 61010:
Safety requirements for electrical measurement, control and laboratory instrumentation.
- IEC 61326:
Electromagnetic compatibility (EMC requirements)
- NAMUR
Standardization association for measurement and control in chemical and pharmaceutical industries. (www.namur.de)
- NEMA
Standardization association for the electrical industry

Index

C

CE-marks	7
Commubox FXA 191	10
conformity description	7
Customer-specific linearization	15

D

Dimensions	7
------------------	---

F

Fault code	20
FIFO active	12

H

HART® function matrix	14
HART® hand operating module DXR 275	10
HART® protocol	11
Hazardous areas	6

I

Installation angle	7
Installation point	7

L

legend plates	7
---------------------	---

M

Measurement range excess	12
Measurement range undercut	12

S

Safety Instrumented Systems (SIS)	6
Safety Message	5
Sensor break	12
Sensor Checkout	20
sensor short circuit	12

T

Technical advancement	6
Terminal layout	9

W

Windows NT® Version 4.0	12
Windows® 2000	12
Windows® XP	12

For Weed instrument contact
call 1 800 880 9333
Internet: www.weedinstrument.com